

The **AGRICULTURAL EDUCATION** *Magazine*

VOLUME 34

SEPTEMBER, 1961

NUMBER 3



Picture legend, page 52

*Featuring—*Materials and
Methods

The Agricultural Education Magazine

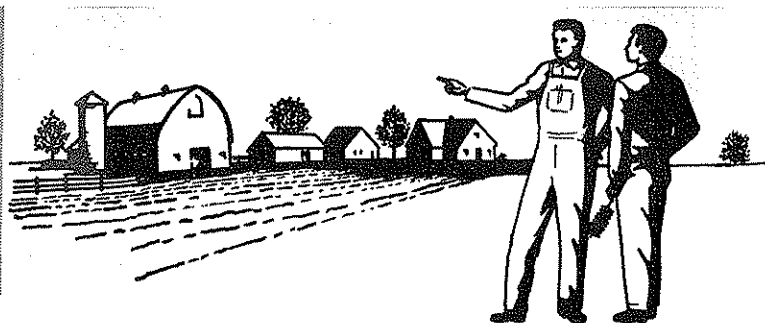

A monthly magazine for teachers of agriculture. Managed by an editorial board chosen by the Agricultural Section of the American Vocational Association and published at cost by Interstate Printers and Publishers, Danville, Illinois.

THE INTERSTATE  DANVILLE, ILLINOIS

MANAGING EDITORS

T. W. Gandy, Auburn University, Auburn, Alabama
Editor
A. H. Krebs, University of Illinois, Urbana, Illinois
Consulting Editor
Henry TenPas, Oregon State College, Corvallis, Oregon
Business Manager

SPECIAL EDITORS

CENTRAL
Ralph J. Woodin, Ohio State University, Columbus, Ohio
R. J. Agan, Kansas State University, Manhattan, Kansas

NORTH ATLANTIC
Joe P. Bail, Cornell University, Ithaca, New York
Jesse A. Taft, State Department of Education, Boston, Mass.

PACIFIC
S. S. Richardson, Utah State College, Logan, Utah
Howard Christensen, University of Nevada, Reno, Nevada

SOUTHERN
J. C. Atherton, University of Arkansas, Fayetteville, Ark.
A. J. Paulus, University of Tennessee, Knoxville, Tenn.
C. C. Scarborough, North Carolina State College, Raleigh, N. C.

AT LARGE
Robert Howey, Sycamore, Illinois
Teachers
Carl F. Lamar, University of Kentucky, Lexington, Ky.
Book Reviews
H. N. Hunsicker, U. S. Office of Education, Washington, D. C.
Vocational Division

SPECIAL REPRESENTATIVES

Pacific, Ralph W. Canada, Fort Collins, Colorado
Southern, S. L. Sparkes, Nashville, Tennessee
North Atlantic, Cola D. Watson, Montpelier, Vermont
Central, R. J. Agan, Manhattan, Kansas
N.V.A.T.A., W. S. Weaver, Delphi, Indiana

EDITING-MANAGING BOARD

Ralph W. Canada, Colorado; S. L. Sparkes, Tennessee; Cola D. Watson, Vermont; R. J. Agan, Kansas; W. S. Weaver, Indiana; W. T. Spanton, Washington, D. C.; G. P. Deyoe, Illinois; Floyd Johnson, South Carolina; Henry TenPas, Oregon; A. H. Krebs, Illinois; T. W. Gandy, Alabama.

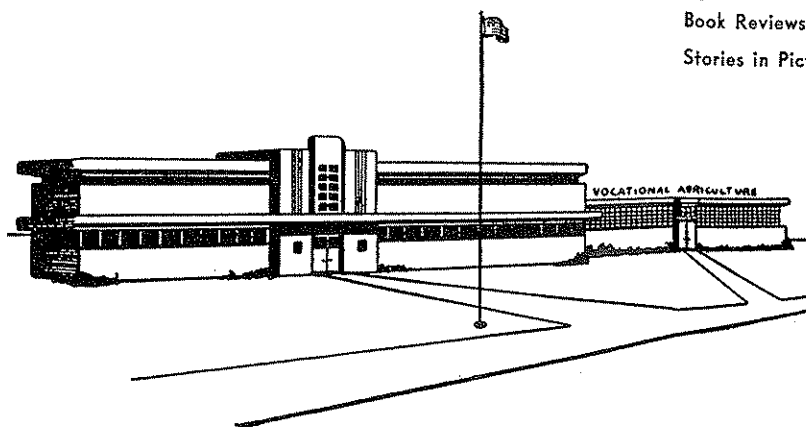

Contents

Editorials

Learning from the Environment	J. E. Deloney	51
Where Is the Frontier in Methods?		51
The Cover Picture		52
Quotations on Education		52
Classroom Observation for Cadet Teachers	Dwight L. Kindschy	52
Charts: Preparation, Preservation and Storage	J. J. Paterson	53
Doing to Learn	Don Hohman	55
Agricultural Service Occupations	E. W. Foss	56
Future Themes		57
Teacher Activities and the Completion of Productive Enterprise Projects	Ralph R. Bentley and Carl F. Scott	58
Audio-Visual Aids in Adult Education	Arol Hudson	60
Book Reviews		61
Tips That Work		62
Is the Fair Booth Worthwhile?	E. M. Webb	63
Effective On-Farm Instruction of Adult Farmers	Rolf Moeckel	64
Keep Records of Your Resources	Burl Hunt	66
Use Local Materials in Teaching	Jimmie G. Lawrence	67
What About Your Next Exhibit?	W. T. Adair	68
Farm and Home Planning	Irving C. Cross	69
Professional Improvement on the Local Level	Elmer L. Cooper	70
New Address for NVATA		71
Tips That Work		71
Book Reviews		71
Stories in Pictures		72

Subscription price, \$2.00 per year, payable at the office of the Interstate Printers and Publishers, 19-27 N. Jackson St., Danville, Illinois. Foreign subscriptions, \$2.25. Single copies, 20 cents. In submitting subscriptions, designate by appropriate symbols new subscribers, renewals and changes in address. Contributions should be sent to the Special Editors or to the Editor. No advertising is accepted.

Second-class postage paid at Danville, Illinois.

Learning from the Environment

J. E. DELONEY, Teacher Education
Auburn University, Auburn, Alabama

The principle in psychology that a person is the product of his environment is certainly a valid one. It is common knowledge that a student learns from his environment. The colonial Indians made beautiful arrow heads out of flint and this skill has been passed on from generation to generation. In fact, it was a part of the Indians' environment. The typical child in the public school would be lost if he were given the assignment to forge an arrow head out of flint. But this is not to say that he could not learn to do it. A good teacher could teach him by enriching his environment so that he would be brought into contact with this phase of proposed learning. It can be said then that a person learns from his environment.

The question might be asked, "How does a person learn from his environment?" The Creator of man provided him with senses. Psychologists are not sure of how many senses, but we do know of the five common ones; namely, seeing, hearing, taste, touch and smell. The student makes contact with his environment through one or more of these senses.

The job of the teacher of vocational agriculture involves teaching high school boys and young adult farmers new and improved ways of farming. If these new and improved ways of farming have not been a part of the student's environment, effective teaching dictates that it be made a part of the environment. This can be done through the medium of teaching materials. A good motion picture in color can show the added beauty of a field of corn that has been properly fertilized as contrasted to a plot that has not had proper fertilization, when demonstration plots are out of season. The contents of microscopic slides can become part of the class environment as they are projected in the classroom. Charts, graphs, demonstrations, chalk boards and other materials of instruction add to the richness of the learning environment and hence enhance the learning process through enriching the environment. The student makes contact with these ideas through his senses. □

Aristotle — All who have meditated on the art of governing mankind have been convinced that the fate of empires depends on the education of youth.

From the Editor's Desk . . .

Where Is the Frontier in Methods?

Most of us have been introduced to a wide range of teaching methods involving many different procedures and materials. Most of these methods are good if used in the correct place and at the proper time. But do we know how and when to use them? The writer suggests that the frontier, the growing edge, is and must be in the people who use teaching methods rather than in the methods themselves. A method of teaching is no better than the use made of it by a teacher. Getting teachers to use wisely the methods we already know is the problem, the frontier, the place where much study and effort must be expended in the future.

Recently, the writer received a request from a young librarian for a filmstrip to show to a group of young children during the library "story hour." In her words the filmstrip would stimulate the children to want to read the story with which the filmstrip was concerned. The wisdom of this position is doubtful; in the experience of the writer it has been the opposite. A film or filmstrip can very effectively tell a story and enrich the reading process, but in many instances it may eliminate the desire to read the story upon which it was based. Perhaps a better use of the filmstrip could be found along with a more effective method of introducing to young readers the value of reading.

At the risk of belittling a growing idea in the field of education (and certainly this is not my intention), the method of *team teaching* is being proposed as a new and revolutionary method. We have known of the concept of "team teaching" for many years, actually since the concept that "two heads are better than one" came into being. Growth is taking place in the further development of the idea, however, and this is important. But my point with regard to the *frontier* is that the success of team teaching will depend upon the teachers and upon their dedication to the idea. The method has been well thought out and completed. Now, the problem lies in getting teachers to accept, to adopt, to follow that which is known.

Many of us, while enjoying and appreciating group discussion in the classroom, fall victim to continuing the use of group discussion at the expense of other more effective methods. There are times when certain information must be imparted before good discussion can take place. This need can sometimes be filled by the lecture method. However, lecturing can become

Where Is the Frontier?

habitual with us when we let ourselves slip into the dangerous position of feeling that we must "get across" a definite amount of facts.

These illustrations are intended to show that the need in the field of methods is not always new methods. Rather, the need is to get people to understand more fully and completely the methods already in existence. This is not to say that we do not need to design and to search for more effective ways with which to stimulate the learning process.

Thus, the question, "Where is the frontier in methods?" leads the writer again and again to the decision that the frontier is in our ability to use the methods already known. □

The Cover Picture

The cover picture was taken by the Photography Center, University of Idaho, Moscow, Idaho, using a new technique that outlined the important part of the picture by a shadow foreground. The picture shows two cadet teachers observing a class of vocational agriculture in the Moscow, Idaho, High School conducted by Kirk Rush.

For a full discussion of the picture see the article following by Dwight L. Kindschy entitled, "A New Look at Classroom Observation for Cadet Teachers."

Martin Luther — When
schools flourish, all
flourish.

Quotations on Education

Diogenes—The foundation of every state is the education of its youth.

H. G. Wells—Human history becomes more and more a race between education and catastrophe.

Addison—What sculpture is to a block of marble, education is to the soul.

Baruch—Every man has a right to his own opinion, but no man has a right to be wrong in his facts.

Henry Adams—A good teacher affects eternity; he can never tell where his influence stops.

A New Look At—

Classroom Observation For Cadet Teachers

DWIGHT L. KINDSCHY, Teacher Education,
University of Idaho

There has always been some question as to the best way cadet teachers can utilize the vocational agriculture department located in the same city as the teacher training institution. In many cases, the public school system in a college town is over-used in relation to the student teaching program. Most authorities will agree that high school students who have several student teachers do not always represent a normal situation in regard to classroom rapport. The students have a way of becoming wise to inexperience which can cause difficulty not only for the cadet but also for the supervising teacher and the school system.

In the fall of 1955, Kirk Rush, who is capable and experienced, accepted the position of vocational agricultural teacher in the high school at Moscow, Idaho. Moscow is also the home of the University of Idaho where agricultural education majors receive their training. Mr. Rush was interested in working with cadet teachers and had helped

many through their student teaching experience. Additional

salary for the Moscow position was made available through the University and the Idaho State Board for Vocational Education so that an observation center for cadet teachers in agriculture could be established.

During the junior year, each cadet in agricultural education at the University of Idaho is required to observe ten hours of class work in the Moscow department of vocational agriculture. This observation program is one of the requirements in connection with a course in agricultural education dealing with teaching methods. The first step in launching this observation program is a field trip at the beginning of the semester by the entire class to the Moscow department for an hour of orientation. During this hour, the cadets have an opportunity to become acquainted with the organization of the agricultural department. The

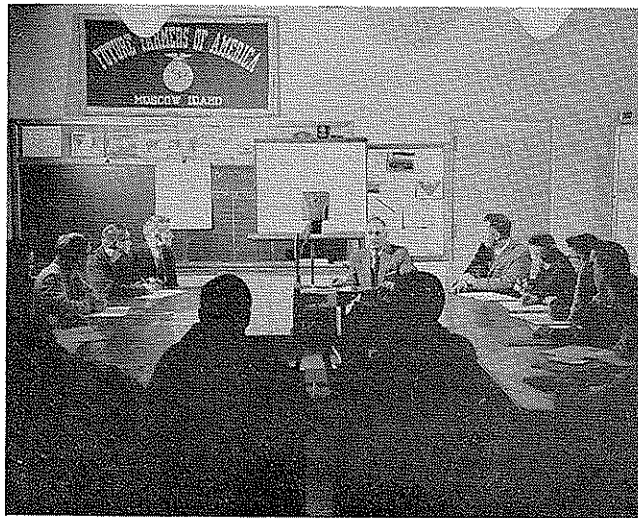

Cover Picture

methods of storing tools, equipment and supplies are explained, and the cadets are shown where state reports, inventories, requisitions, and other records are kept. Another very important part of the field trip is an explanation of what will be expected of the cadets during their observation sessions.

Many teacher education institutions require their cadets to observe classes, but the cadets are usually only asked to observe the class from a chair in the back of the room and at the close of the period they quietly leave with the students. This is not the way it is done in the Moscow agricultural department. The cadets must first sign a reservation sheet in the Agricultural Education office at the University of Idaho to insure that only two cadets will be observing any one particular class. The cadets must be present

before the class they observe begins and, upon arrival, they take their observation sheets out of the teacher's file and place it on his desk. This procedure enables the agricultural instructor to learn the cadet's name and it also simplifies the task of crediting the cadet with an hour of observation.

In the classroom that is used for observation, the tables are placed in the familiar U and at the head of the table arrangement, on each arm of the U, a chair is reserved for the observing cadet. The instruction desk is placed in the usual place between the two arms of the U. This arrangement places the two cadets in the front of the room, one on either side of the instruction desk. While teaching the class, the agricultural instructor includes the cadets in the discussions, often asking for their opinions on various subjects. During the supervised study period, the cadets are given an opportunity to help students with their various class problems.

If a shop class is being observed, the cadets are provided with coveralls and encouraged to participate in the shop activity.

The procedure that has been outlined is the key to the success of this observation program. The high school students usually accept the cadets as assistant teachers. The cadets themselves gain much more from this type of observation period because they are able to participate in the class process. The feeling that strangers are in the room to witness a performance is not present because the cadets themselves take part in the action. No advanced preparation is required of the cadet but rapport is present because the cadet is accepted as belonging to the class group.

An unexpected additional benefit has developed from this observation program, because the cadets have an opportunity to learn to know the individual students in the Moscow department. In some cases, the stu-

dents have invited the cadets to visit their homes and inspect their project programs. The cadets sometimes keep in contact with the high school students even after their observation period is completed.

It must be remembered, however, that in order to organize a successful observation program of this kind the cadet teachers must be properly prepared. Both the teacher trainer and the instructor in charge of the observation department have a responsibility in building the right attitude and enthusiasm in relation to both the cadet teachers and the high school students enrolled in the observation department. It is not advisable to use the observation department extensively for student teaching as the two programs are different in character. The experience gained by the cadet in completing his actual student teaching in another department which is located away from the campus is invaluable. □



Charts: Preparation, Preservation & Storage

J. J. PATERSON, Agricultural Engineering, Southern Illinois University,
Carbondale, Illinois

A large number of charts is available from various sources on a variety of subjects. A list of sources is included at the end of this article. Such charts are valuable instructional material if kept in such a way so as to be quickly and easily available. For farm power and machinery, shopwork, and for engineering in general, charts are particularly useful to show mechanical details. It also happens that there is a large number of charts to be had in these fields.

In many schools and colleges visited by the writer over the years, charts seem to be a problem. They are usually unrolled each time before use and held up with tacks or tape, finally becoming so smudged and torn as to be unreadable, or if posted permanently on a wall, they cannot be moved easily. In all cases, proper storage and preservation would en-

sure much better use of chart material.

For many years it has been a special interest of the writer to collect all suitable charts available, particularly in shopwork and in farm power and machinery.

Most charts are printed on heavy paper in black and white or in colors. Some more expensive ones are on varnished paper. In general, it will be more satisfactory to paste all paper charts on heavy paper board about 3/16" thick.

Preparation and Preservation

The step-by-step procedure in making a neat and satisfactory job is as follows:

1. Collect a dozen or so charts before starting.
2. Use 3/16" "Upson" or other

similar paper board obtainable from lumber yards; Four foot by eight foot sheets are about \$3.00.

3. Size both sides with glue size to reduce the suction when pasting and allow to dry.

4. Lay charts out on sheet so that charts of about equal size and on similar subjects are on opposite sides. If charts are to hang permanently on a wall, use only one side.

5. Paste charts on one side only and allow to dry before pasting the other side. Use ordinary wallpaper paste (about 30¢ per lb. at any paint store). Put paste on back of *chart* and also around the outer edge of the board where chart will be. Apply the paste evenly. Apply charts carefully, smoothing out by hand for at least 4-5 minutes from center outward to remove all air bubbles. Watch the edges especially. (Paper will stretch

CHART RACK.

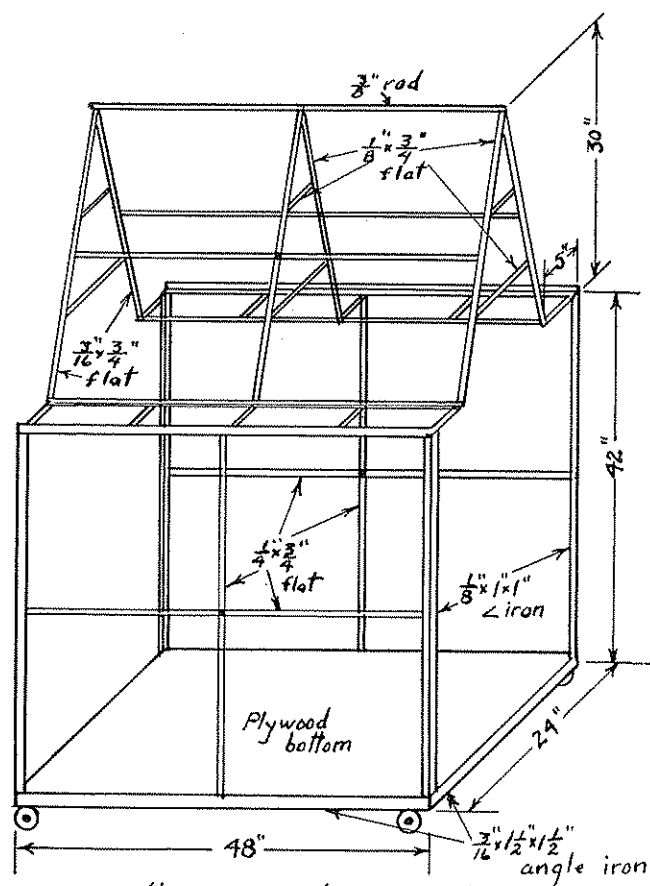

Note - Use 2 wheels and 2 casters.

CHART STAND.

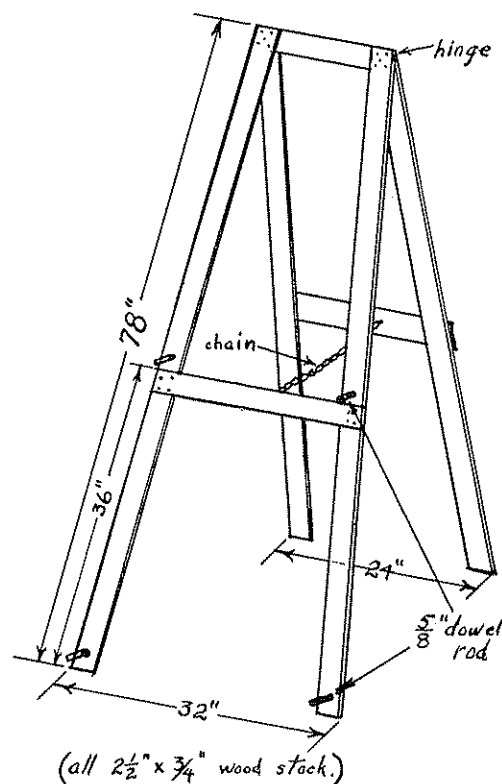

(all $2\frac{1}{2} \times \frac{3}{4}$ wood stock.)

J.J. Paterson, Sept/60
S.I.U. Carbondale, Ill.

for about 5 minutes, and if smooth, it will then shrink again into a smooth job.)

6. Cut charts apart in the rough with hand saw or skill saw, then trim carefully to size on a power saw.

7. Paste chart on other side if required.

8. Bevel all corners and all eight edges on power grinder. This is quickly done and helps prevent tearing at the edges later.

9. Clean off paste smudges with moist cloth.

10. Brush or spray on a solution of carboxy-methyl-cellulose to seal surface and prevent the varnish or lacquer from soaking in. Be sure that the chart is evenly coated.

11. Allow to dry, then spray on either white shellac, clear white or clear finish lacquer and allow to dry. Varnish is good also. Do not use shellac in humid climates or charts will stick in storage.

A smooth clean job will result if proper care is taken. Probably the most important step is the use of the carboxy-methyl-cellulose solution to

prevent the dirty brown appearance which would otherwise result. This material comes in the form of a white powder, and is obtainable from large paint manufacturers at about \$1.00 per lb. Even large retail or wholesale paint stores do not carry it. It must be mixed with water (about a tablespoon per pint of water) a day or two in advance. The resulting clear liquid should be thin enough to brush well but not watery. It may be applied to paper of any kind to seal the surface. It should be sprayed on charts made with drawing ink, as a brush would smudge. This solution seals the surface so that the lacquer or varnish will not soak in.

Plastic coatings in pressure cans are available. While these are satisfactory for small jobs, they are much too expensive for any sizeable number of charts and produce a less glossy and smudge resistant surface. They do, however, eliminate the preparation and application of the carboxy-methyl-cellulose. In the writer's opinion, the latter material is much superior and cheaper.

Charts on varnished paper should first be soaked in a bathtub for an hour or so and allowed to drip until just damp.

Charts on one side only will tend to bow with the shrinkage of the chart in drying. Weighting on a flat surface will prevent this, or a wooden frame grooved for the edge of the chart is still more permanent.

Storage

After the charts are made, they can be most effective only if properly stored and displayed. A portable chart rack will hold up to 100 charts or more and provide space for display has been found very useful (see plan). A sheet of plastic will keep off dust when charts are not being used.

Extra display space can be easily and cheaply provided by one or more chart stands. These will hold two charts, one above the other.

The methods and materials described above have been effectively used by the writer for the last fifteen years with complete success, provided each step is carried out as

outlined. It is hoped that this description will help solve a problem for others in the same or other fields.

Some Sources of Charts

Farm Power and Machinery

1. Allis-Chalmers
2. Briggs & Stratton Corp.
3. Caterpillar Tractor Co.
4. Deere & Company
5. Ensign Carburetor Co.
6. Ethyl Corp.
7. Ford Tractor Company
8. Fram Oil Filters
9. General Motors Corp.
10. Illinois Farm Supply
11. International Harvester Co.

12. J. I. Case Company
13. Marvel Schebler Products Division (Borg-Warner Corp.)
14. Massey-Ferguson
15. Oliver Farm Equip.
16. Successful Farming
17. University of Nebraska (Neb. tests)
18. Zenith Carburetor Co. (Bendix Corp.)

Engines & Parts

1. A-C Spark Plug Division (General Motors Corp.)
2. Briggs and Stratton Corp.
3. Caterpillar Tractor Co.
4. DeLuxe Products Corp.
5. Donaldson Co.

6. Ensign Carburetor Co.
7. Ethyl Corp.
8. Fram Oil Filters
9. Illinois Farm Supply
10. Marvel Schebler
11. Zenith Carburetor Co.

Shopwork

1. Air Reduction Sales Co.
2. Atlas Press Co.
3. Henry Disston & Sons
4. Lincoln Electric Co.
5. Lufkin Rule Co.
6. L. S. Starrett Co.
7. Nicholson File Co.
8. South Bend Lathe Works
9. Stanley Tool Co.
10. Tempil Corp.



Doing to Learn

On the School Farm

DON HOHMAN, Vo-Ag Instructor, New London, Wisconsin

As we gaze into the crystal ball to visualize the problems that young men studying vocational agriculture now will be faced with in their lifetime of farming, we must try to prepare these young men with as many experiences as we can.

We, in our typical Wisconsin dairy community of New London, feel duty bound to provide as many learning experiences as possible. We subscribe to the idea of a school farm and feel it is the ideal teaching atmosphere. However, it is not feasible in our community, so we are trying to come as close to this ideal situation as possible.

Our Board of Education purchased 27 acres of good soil for the site of a new high school. This land in the past had been in crop land and produced abundantly and is ideally located just two blocks from our present high school.

Our Future Farmer Chapter has been granted permission to use this land for several years. Joe Walker, our County Agent, has contacted the University of Wisconsin College of Agriculture for assistance. We will be planting grain test plots, alfalfa variety plots, corn variety plots, fertilizer demonstration plots on corn,

weed control plots and cultivation demonstrations.

We will receive professional guidance from the college staff and will face the many problems after careful deliberation. On each problem the young men of our department will be given the opportunity to make de-

isions. The teaching situations are multiple and we will try to capitalize on each opportunity.

Late in the summer we plan to hold a field day for the students and their parents as well as any other interested farmers. We realize the amount of work involved and the



FFA members receiving instruction in care and adjustment of the disc.

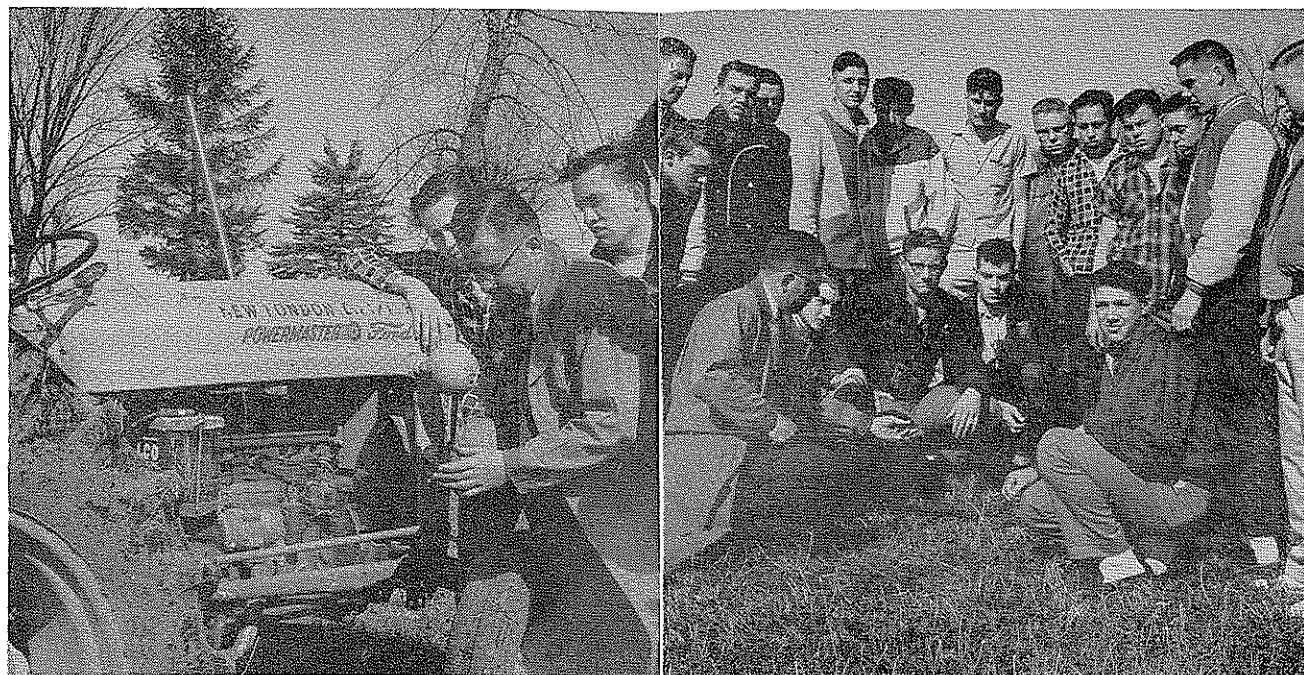

Checking the Chapter owned tractor.

A demonstration in taking soil samples.

headaches and misfortunes we will encounter but we also realize the opportunities.

Our chapter members have had no small measure of experience in buying and managing land and equipment, as we presently own 200 acres of marginal land. Our chapter has planted 140 acres of this land to trees and own a tractor and a full line of farm machinery. This has been accomplished over a thirteen year period

because our community, from the school administration and board of education down to the newest green hand, have all pitched in to help with these various projects in order to provide real and adult experiences for young men.

One might ask what has been the result of this type of teaching. Our graduating vocational agriculture seniors have had many experiences they could not get in textbooks. They

know how to budget and manage finances in a challenging way; they have had much experience in making practical decisions; they have learned to accept responsibility; pride of ownership is theirs; they have learned to accept disappointments; they have tasted success, and have a real pride of accomplishment. Truly these young men have been given a chance to *Learn by Doing*. □

Agricultural Service Occupations

An Added Area for Agricultural Education

E. W. FOSS, Professor, Agricultural Engineering, Cornell University

A recent release from the U.S. Department of Health, Education, and Welfare has encouraged discussion of educational needs for training in agricultural service occupations. My plea, here, is to (1) recognize this need area as separate from training for farming, and (2) develop a high school program geared for this need.

With some 30 per cent of our population engaged in agribusiness, and with colleges of agriculture advertising the opportunity to place approximately twice their present graduates, let's get busy aiming our boys toward this goal of college training in agriculture. The largest segment of our population, as split by the Ladder of

Occupations, is in the operative and skilled craft categories. There are thus required millions of present and future rural skilled workers with a continuing need for guidance and training. Many of these occupations are based on skills taught in your agricultural mechanics courses, but requiring greater emphasis and range.

For several years I have felt that the following program would provide revitalization in vocational agriculture:

1. Continuation of vocational agriculture in its present form for training for farming in farm communities and rural area vocational schools.

2. A ½ or 1 year guidance course providing the broadest concept of

agribusiness for freshmen, designed mostly for those pupils planning to enter college and those going to 1-3 year post secondary technical schools.

3. A major 3 year full time sequence in agricultural mechanics to provide trade training in rural areas until area vocational schools can be established.

4. Special courses for particular areas that require large numbers of workers in forestry and forest industries, ornamental horticulture, food sales and technology, etc.

To implement these changes I would recommend that two programs be offered in the teacher training departments—agricultural science and

The Occupational Ladder

% of 1950 Population and Category	Type of Work	Salary or Wage	Education Required	Examples of Agr. Business Occupations		
				Agr. Supplies	Farming	Process. & Dist.
8.5%	Administration	\$10,000 - up	4 Yr. College + Graduate Study + Experience	Cooperative Dept. Head	Corporation Farm Administrator	Birdseye Snyder Dept. Head
	Profession	\$5,000 - up	4 Yr. College + Graduate Study	Petroleum Agr. Service	Corporation Farm Adviser	Adviser
	Technician	\$4,000 - \$8,000	Technical School	Art. Breeding	Cattle Buyer or Showman	Research Aid
8.6%	Manager	\$5,000 - up	High School → College + Experience	Farm Mach. Agency	Owner-Operator	Poultry Dressing Plant Owner-Operator
6.9%	Sales	\$2,000 - up	High School → College	Fertilizer	Roadside Stand	Swift & Company
13.8%	Skilled Craftsman	\$3,500 - \$6,000	High School → Trade School + Experience	Farm Mach. Repair	Dairy Herd Tester	Meat Boning
17.8%	Operative (S. Skilled)	\$3,000 - \$4,000	High School	SC.S, Bulldozer Operator	Tractor Operator	Machine Operator
10%	Laborer	\$2,000 - \$3,000	High School	Pick and Shovel	Barn or Field Help	Day Help

agricultural mechanics. The agricultural science major would provide an additional certification in science teaching, and the agricultural mechanics major would provide an additional certificate in industrial arts. These two men in any school system, each employed 1/2 time as vocational agriculture teachers, could thus be more specialized and at the same time be extremely versatile in terms of the percentage of teaching time in science and agricultural science and in agricultural mechanics and industrial arts. We have too long (with tongue in cheek) asked each vocational agriculture teacher to try to become proficient in most of the departments in the College of Agriculture. This proposal is an ideal way to cut the requirements in half and make better use of each prospective teacher's talents. This combination, with the proposed program changes, makes full use of the agriculture classroom, agricultural science laboratory, and agricultural mechanics shop with no dual, split, or shared work areas. Opportuni-

ties for adult education and field supervision are likewise strengthened.

In the past three years, as a member of the College of Agriculture Petitions Committee, it has been my duty to pass judgment on boys who were having a hard time. Too frequently the courses were mathematics, physics, and chemistry usually required for programs in veterinary medicine, agricultural engineering, agronomy, food technology, biochemistry, and other attractive fields. As teachers of vocational agriculture in your community, you are best fitted to guide boys to colleges for these and other careers. Unless you insist upon 3 to 4 years of high school mathematics, plus physics and chemistry, you will be guilty of sending these boys to college with less than the best preparation. In my opinion it is time to make the separation in your high school agriculture courses by providing separate guidance courses in agribusiness for college entrance students. In most instances there is not sufficient high school time

to ask college bound boys to take three or four years of agriculture plus their other needed subjects.

Space is too short to elaborate on the three year agricultural mechanics program. However, the magazines and papers are full of expressions of need for trade training in rural areas, yet a decade or more will go by before area vocational schools can become established. In many parts of the country the population is too sparse for such a school in the predictable future. While no agricultural mechanics program can compare with a standard vocational trade program, a three year sequence of double (even single) periods devoted to wood, concrete, metal shop, welding, and repair trades will provide basic skills, guide many boys into the trades, and hold rural boys not interested in farming from dropping out.

I don't expect this to be a "cure all," but I do feel the program has a wide potential. What do you think? □

FUTURE THEMES

October—Lay Participation

November—The Impact of Industrialization on Vo-Ag

December—The Effect of Vo-Ag on College Success



Teacher Activities and the Completion of Productive Enterprise Projects



RALPH R. BENTLEY, Teacher Education, Purdue, and
CARL F. SCOTT, State Supervision, Indiana

Are you satisfied with the farming programs of your students? Do they complete a high percentage of the productive enterprise projects they undertake? Why does the average number of productive enterprise projects completed per student vary so widely from school to school?

In an attempt to secure information which would aid in answering the last question, a research study was designed and carried out by the authors. The primary purpose was to determine whether there were significant differences between the activities of teachers, related to supervised farm-

ing, in schools where students complete a relatively high versus a relatively low average number of productive enterprise projects.

Design of the Study

The data were collected by a questionnaire consisting of 55 teacher activity statements which were assumed to have particular significance with respect to the planning and conducting of farming programs. Sample teacher activity statements and directions for responding to the questionnaire are illustrated below:

The 55 teacher activity statements included in the questionnaire were categorized according to (1) requirements, (2) classroom techniques and procedures, (3) home and farm relationships, (4) Future Farmers of America, and (5) awards.

The questionnaire was submitted to 100 of the 181 Indiana vocational agriculture teachers who had a tenure of three or more years in their present teaching positions. Fifty of the 100 teachers were from schools where the students completed a relatively high average number (range 2.04-4.96) of productive enterprise projects and 50 were in schools where the students completed a relatively low average number (range .39-1.22).

The respondents were classified as either "high" or "low" dependent on the average number of productive enterprises completed by their students. In analyzing the data the responses "always" and "usually" were combined as were the responses "rarely" and "never." Frequencies and percentages were then computed for the "high" and "low" groups.

The chi-square technique was used to ascertain whether or not there were significant differences between the responses of teachers in the "high" and "low" completion schools for each item in the questionnaire.

Teacher Activities Related to Supervised Farming in Vocational Agriculture

Instructions: For each statement decide which one of the following words, "Always," "Usually," "Sometimes," "Rarely," "Never," best describes your activities with supervised farming.

- "A" stands for *Always*
- "U" stands for *Usually*
- "S" stands for *Sometimes*
- "R" stands for *Rarely*
- "N" stands for *Never*

Thus, if you never show pictures of the supervised farming activities of your students at P.T.A. meetings, you should encircle the "N" on the right of the statement. Below is a sample statement with response encircled.

"Show pictures of the supervised farming activities of my students at P.T.A. meetings." . . . A U S R N

In selecting your answer, consider the answer words as if they were points on the same straight line.



Note that the words "Always" and "Never" are not on the exact ends of the line.

Use "Always" if you cannot quickly remember any time you did not use the activity.

Use "Usually" if the activity is used much more than 50% of the time.

Use "Sometimes" if the activity is used about 50% of the time.

Use "Rarely" if the activity is used much less than 50% of the time.

Use "Never" if you cannot quickly remember having used the activity.

ANSWER KEY: "A"—Always, "U"—Usually, "S"—Sometimes, "R"—Rarely, "N"—Never

1. Require that the students have opportunities for supervised farming before they are permitted to enroll in vocational agriculture A U S R N
2. Check Farmer Training Books when making on-farm visits during summer months A U S R N

Findings

Of the questionnaires sent to the 50 teachers in the "high" completion group, 88 per cent were returned; whereas, 58 per cent were returned by the 50 teachers in the "low" completion schools.

Table I shows the teacher activity statements, the percentages of teacher responses for the "high" and "low" completion schools, and the statistically significant chi-square levels which satisfied the .05, .01, and .001 levels.

It will be noted that the percentages of responses of the teachers in

- 3. Arrange and conduct supervised farming tours for my students and their parents A U S R N
- 4. Guide my students in studying the supervised farming programs of those who have earned the American Farmer Degree A U S R N
- 5. Urge my students to select supervised farming programs which include both livestock and crops enterprises A U S R N

TABLE I

TEACHER ACTIVITIES AND THE COMPLETION OF PRODUCTIVE ENTERPRISE PROJECTS

Activities	School Group	Percentage of Responses			Chi-Square
		A+U ¹	S ¹	R+N ¹	
A. REQUIREMENTS					
1. Have all of my students use the Indiana Farmer Training Book.	High ²	100	0	0	
	Low ³	93	7	0	
2. Have beginning students select their productive enterprise projects early in the school year.	H	98	2	0	
	L	97	0	3	
3. Require that the students have opportunities for supervised farming before they are permitted to enroll in vocational agriculture.	H	95	0	5	
	L	79	7	14	
4. Require that my students have one or more improvement projects.	H	93	5	2	
	L	85	7	7	
5. Require that my students have several supplementary farm practices.	H	93	2	5	
	L	79	10	10	
6. Require that my students have more than one productive enterprise project.	H	93	2	5	23.58*
	L	41	41	17	
7. Require that all students have in progress satisfactory supervised farming programs before they are permitted to re-enroll in vocational agriculture.	H	89	0	11	10.36**
	L	66	21	14	
8. Have my advanced students summarize completed supervised farming activities early in the school year.	H	82	14	5	5.98***
	L	59	21	21	
9. Check project plans before the students enter them in their Farmer Training Books.	H	73	16	11	
	L	69	17	14	
10. Have students read supervised farming stories in magazines such as the Future Farmer Magazine, The American Farm Youth, and other farm magazines.	H	59	27	14	
	L	55	28	17	
B. CLASSROOM TECHNIQUES AND PROCEDURES					
11. Urge students to select supervised farming programs which include both livestock and crops enterprises.	H	100	0	0	
	L	97	3	0	
12. Guide my students in keeping complete and accurate supervised farming records.	H	100	0	0	
	L	90	7	3	
13. Guide my students in estimating the expenses and receipts for the enterprises which are being considered for their supervised farming programs.	H	100	0	0	
	L	90	7	3	
14. Have class instruction, early in the school year, that deals with the nature and purpose of supervised farming.	H	98	2	0	
	L	93	3	3	

(Continued on page 60)

the "high" and "low" groups were significantly different for 17 of the 55 teacher activities and that in each instance the "high" group performed the activity more frequently than did the "low" group. It will also be noted that the percentages of responses for nearly all other teacher activities favored the teachers in the "high" completion group. Table II shows the distribution of the 55 teacher activity statements by categories together with the number and proportion of significant differences.

The teacher activity statements where significant differences between the "high" and "low" completion groups were found are listed by categories in the following paragraphs:

Requirements—"Require that my students have more than one productive enterprise project," "Require that all students have in progress satisfactory supervised farming programs before they are permitted to re-enroll in vocational agriculture," and "Have my advanced students summarize completed supervised farming activities early in the school year."

Classroom Techniques and Procedures—"Base my classroom instruction on the supervised farming needs of the students" and "Guide my students in using the records of their completed supervised farming programs as a basis for planning the current years program."

Home and Farm Relationships—"Visit my students and their parents on the farm before the students begin their course work in vocational agriculture." "Discuss the purposes of supervised farming with the parents of students before they begin their first year in vocational agriculture." "Assist my students in locating animals, seed, supplies, equipment, facilities, or other materials needed to carry on their supervised farming programs." "Guide my students with the assistance of parents in planning long-time supervised farming programs." "Guide my students with the assistance of parents in making definite business agreements for their productive enterprise projects."

Future Farmers of America—"Encourage my students to work for the Hoosier Farmer Degree." "Nominate FFA members for the Hoosier Farmer Degree." "Have had FFA members earn the Hoosier Farmer Degree." "Guide my students in studying the supervised farming programs of those who have earned the State or Hoosier Farmer Degree." "Guide my students in studying the supervised farming

(Continued on page 62)

TABLE I (Continued)

Activities	School Group	Percentage of Responses			Chi-Square
		A+U	S	R+N	
15. Guide my students in summarizing and analyzing the records of their supervised farming activities.	H	95	5	0	
	L	79	17	3	
16. Base school grades given in vocational agriculture on both supervised farming activities and classroom work.	H	93	2	5	
	L	83	7	10	
17. Guide my students in the selection of approved practices to be followed in carrying out each of their productive enterprise projects.	H	93	7	0	
	L	93	7	0	
18. Guide my students in making a survey of enterprises on the home farm.	H	93	5	2	
	L	83	17	0	
19. Guide my students in determining the relative merits and limitations of the various farm enterprises which are being considered for their supervised farming programs.	H	91	7	2	
	L	93	7	0	
20. Base my classroom instruction on the supervised farming needs of the students.	H	86	14	0	6.70***
	L	69	24	7	
21. Guide my students in the preparation of written plans for carrying out each of their productive enterprise projects.	H	84	10	7	
	L	76	10	14	
22. Guide my students in using the records of their completed supervised farming programs as a basis for planning the current year's program.	H	84	7	9	8.60***
	L	55	31	14	
23. Guide my students in establishing goals or standards for their supervised farming programs.	H	77	23	0	
	L	69	17	14	
24. Grade Farmer Training books at regular intervals throughout the school year.	H	75	16	10	
	L	55	21	24	
25. Base part of the student's school grade in vocational agriculture on his summer supervised farming activities.	H	73	7	20	
	L	62	17	21	
26. Guide my students in studying the supervised farming programs of former students who are now established in farming.	H	50	30	20	
	L	24	34	41	
27. Guide my students in studying the supervised farming programs of other students in the school.	H	49	35	16	
	L	34	31	34	
28. Use the classroom bulletin board or other facilities to display supervised farming materials such as pictures, selected supervised farming programs, and summaries of productive enterprise projects.	H	45	41	14	
	L	34	45	21	
29. Use pig chains, crop improvement associations, or other such groups as a means of helping to initiate productive enterprise projects.	H	44	32	23	
	L	38	24	38	
30. Have older or former students tell my vocational agriculture classes about their supervised farming programs.	H	34	39	27	
	L	17	38	45	
C. HOME AND FARM RELATIONSHIPS					
31. Visit my students and their parents on the home farm during the summer months.	H	98	2	0	
	L	100	0	0	

(Continued on page 61)

Audio-Visual Aids in Adult Education

AROL HUDSON, Vo-Ag Instructor,
Vernon, Florida

The theory of learning that is most generally accepted today is that one learns more readily the information most needed by him at the time he has an opportunity to learn. This theory of learning is practiced in all types of education but to a greater degree in adult education than in other types. The newer theory also accepts the belief that learning takes place through experience, and that if learning has taken place there will be a change or modification of behavior. I think most teachers believe that knowledge isn't something we store but is something we do.

Much emphasis is being placed upon adult education today, especially in the vocational agriculture program. If the vocational agriculture instructor expects to teach an adult group, he must provide information needed by the group, and present it in an interesting and effective manner. If this practice isn't followed the group will not continue to meet with the instructor.

Audio-visual aids provide the most effective means of meeting the newer theory of learning in all types of education, and especially in adult classes in agriculture. Many types of audio-visual aids are readily available in the local community; many can be made by the local teacher, and others secured from various sources.

Research has proven that audio-visual aids are a decided help in adult-learning when they are chosen wisely and used properly. The value of audio-visual aids depends upon the way they are used, which means they should not be used as entertainment. The aids chosen at any time must bear directly upon the problem the group has chosen and must be used at just the right time so as not to cause a break in the continuity of thought. The aid must teach something and not just display something. The instructor must plan ahead and use a reasonable number of aids. In some cases too few have been used, and in other cases too many have been used and often improperly used.

The following list mentions some of

(Continued on page 61)

TABLE I (Continued)

Activities	School Group	Percentage of Responses			Chi-Square
		A+U	S	R+N	
32. Visit my students and their parents on the home farm during the school year.	H	93	7	0	
	L	93	3	3	
33. Visit my students and their parents on the farm before the students begin their course work in vocational agriculture.	H	84	16	0	10.76**
	L	55	28	17	
34. Endeavor to have my students select those supervised farming activities which will enable them to gain new experiences in farming.	H	84	16	0	
	L	69	28	3	
35. Discuss the purposes of supervised farming with the parents of students before they begin their first year in vocational agriculture.	H	75	18	7	8.83***
	L	48	17	34	
36. Assist my students in locating animals, seed, supplies, equipment, facilities, or other materials needed to carry on their supervised farming programs.	H	72	23	5	4.48**
	L	48	48	3	
37. Assist my students in selecting animals, seed, supplies, facilities, or equipment needed to carry out their supervised farming programs.	H	70	25	5	
	L	59	41	0	
38. Guide my students with the assistance of parents in planning long-time supervised farming programs.	H	70	20	10	13.09**
	L	31	34	34	
39. Guide my students with the assistance of parents in making definite business agreements for their productive enterprise projects.	H	68	25	7	8.46*
	L	41	28	31	
40. Schedule my farm visits to coincide with critical periods in the student's supervised farming program.	H	68	32	0	
	L	52	34	14	
41. Check Farmer Training Books when making on-farm visits during summer months.	H	61	30	9	
	L	45	41	14	
42. Arrange and conduct field trips in order that my students may observe the supervised farming programs of other students.	H	41	43	16	
	L	28	45	28	
43. Notify or make arrangements with the students and their parents before making on-farm visits.	H	23	39	36	
	L	21	45	34	
44. Arrange and conduct supervised farming tours for my students and their parents.	H	16	25	59	
	L	7	38	55	
45. Hold group meetings for parents of beginning students each year to discuss with them the nature and purpose of supervised farming.	H	11	16	73	
	L	7	10	83	

D. FUTURE FARMERS OF AMERICA

46. Make use of the FFA to promote interest in supervised farming activities.	H	93	5	2	
	L	86	14	0	
47. Encourage my students to work for the Hoosier Farmer Degree.	H	93	7	0	5.89***
	L	72	7	21	
48. Nominate FFA members for the Hoosier Farmer Degree.	H	86	5	9	15.90*
	L	41	21	38	
49. Have had FFA members earn the Hoosier Farmer Degree.	H	68	11	20	18.01*
	L	17	24	59	
50. Guide my students in studying the supervised farming programs of those who have earned the State or Hoosier Farmer Degree.	H	55	27	18	11.06**
	L	17	38	45	

(Continued on page 62)

Audio-Visual Aids . . .

the audio-visual aids that can be effectively used in adult education:

1. Field trips and demonstrations.
2. Motion pictures, slides, and filmstrips.
3. Opaque projector.
4. Overhead projector.
5. Chalkboards, charts and maps.
6. Flannel boards.
7. Bulletins and mimeographed materials.

The teacher of adults should remember that many audio-visual aids can be effectively used to offset any sight or hearing difficulty that adults might have. These aids are of great benefit to the adult learner in that they make it possible for him to use the reasoning ability he has acquired through years of experience.

We as teachers of adult groups must put much effort into the selection, preparation, and use of audio-visual aids if the learner is to receive the maximum benefit from these materials.

BOOK REVIEWS

ANIMAL HUSBANDRY: ANIMAL HUSBANDRY HERESIES by Allen Frazer. Published by Philosophical Library Inc., 15 East 40th Street, New York 16, New York, 200 pp. 1961. Price \$6.00.

Animal Husbandry Heresies is not a textbook of animal science. It is the personal views of one man who has attempted to reconcile orthodox agricultural science with his own observations on the farm. He doubts whether in its essentials the breeding of animal has changed so materially since long before Bakervill's time.

The author believes that the geneticist and the breeder tend to exaggerate the importance of breeding in relationship to environmental factors. He shows how progeny testing and sire performance test have been practiced for centuries.

The book has been divided into four areas. (1) Inheritance, (2) Environment, (3) Husbandry, (4) Purpose. Included in each area are numerous chapters that relate the authors personal views and anecdotes, combined with his own observations over a period of forty years.

This book will make interesting reading by practical farmers, but will be criticized by geneticists and purebred livestock breeders.

Howard Bradley
Teacher Education
Kansas

TABLE I (Continued)

Activities	School Group	Percentage of Responses			Chi-Square
		A+U	S	R+N	
51. Guide my students in studying the supervised farming programs of those who have earned the American Farmer Degree.	H	35	23	41	6.23***
	L	14	28	59	
E. AWARDS					
52. Give local recognition and awards each year to outstanding vocational agriculture students at FFA banquets, school assemblies, or other group meetings.	H	93	7	0	
	L	90	0	10	
53. Give local recognition each year to the student having the most outstanding supervised farming program.	H	86	7	7	
	L	76	7	17	
54. Have the vocational agriculture advisory committee assist me in the selection of students who are to be given special recognition for having outstanding supervised farm practice programs in the local school.	H	77	10	14	10.70**
	L	48	3	48	
55. Provide local recognition and awards each year for those students who have done above average work in supervised farming.	H	68	20	14	8.34***
	L	38	21	41	

¹A+U = Always and usually, S = Sometimes, R+N = Rarely and never.

²Schools where students completed a high average number of production enterprise projects.

³Schools where students completed a low average number of productive enterprise projects.

*Chi-Square—Difference due to chance less than 1 in 1000

**Chi-Square—Difference due to chance less than 1 in 100

***Chi-Square—Difference due to chance less than 5 in 100

Table II

NUMBER AND PERCENTAGE OF SIGNIFICANT DIFFERENCES BY CATEGORIES FOR THE TEACHER ACTIVITY STATEMENTS

Category	Number of Statements	Significant Differences	
		Number	Percentages
Requirements	10	3	30
Classroom Techniques and Procedures	20	2	10
Home and Farm Relationships	15	5	33
Future Farms of America	6	5	83
Awards	4	2	50
Total	55	17	31

(Continued from page 59)
programs of those who have earned the American Farmer Degree."

Awards—"Have the vocational agriculture advisory committee assist me in the selection of students who are to be given special recognition for having outstanding supervised farm practice programs in the local school." Provide local recognition and awards each year for those students who have done above average work in supervised farming.

Implications

1. Special attention should be given to farming program requirements expected of vocational agriculture students.

2. Close working relationships should be established and maintained between the parents, the student and his teacher in planning and conducting the student's farming program.

3. Classroom instruction should be

TIPS THAT WORK

Using a Map of the Home Farm

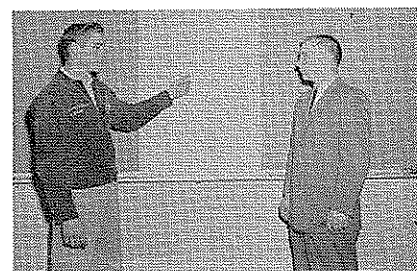

Pictured above is Dean Melius, senior farm management student (left), and Mr. Merlin Newman, vocational agricultural instructor, at Faulkton High School, Faulkton, South Dakota. Dean is explaining his home farm layout to Mr. Newman and the senior class. The map is used by the student in planning his farm arrangement. Each student is required to draw a map of his home farm. After each boy has explained the present drawing to the class, they make new drawings revising the old setup. This gives the boys a better picture of what now exists and how the situation can be changed to make the farm more efficient.

The students use 8½ by 11 inch paper. Each sheet is divided into one-half inch squares to make the drawing easier and more accurate. Each square can represent so many acres.

I find the boys become highly motivated about their home farm and also the drawings add interest to our farm management class. □

Merlin Newman
Vo-Ag Instructor
Faulkton, South Dakota

closely related to the farming programs of the students.

4. Awards may be used to advantage as a means of encouraging students to complete their farming programs.

5. The Future Farmers of America is an important factor in motivating students to complete their productive enterprise projects. □

Is the Fair Booth Worthwhile?

E. M. WEBB, Supervisor, Washington



Each year around fair time, you may observe in many vocational agriculture classrooms evidence of a Future Farmers of America fair booth in the process of development. This activity has been planned long in advance of its actual appearance in the classroom or shop. Many hours of theme planning and of gathering, sorting and storing produce have taken place. The amount of time required to plan and construct a fair booth may cause many to question the value of spending the necessary time and money on such an activity. However, it would be difficult to find a situation where so many people can be reached in so short a time as the county or state fair.

Industrial concerns are willing to pay large sums of money for the privilege of setting up displays of their merchandise at fairs. In most cases, the FFA chapter has the space donated free by the fair management, and, in many cases, a flat sum of \$50, \$75 or \$100 and in some cases even more is given the chapter to cover construction costs. In addition, the chapter may, if its exhibit is good enough, participate in the prize money.

Even if all the above is true, it still may not be justifiable to spend time and money to put up an exhibit in the form of a fair booth unless it contributes to the well being of the students concerned and reflects credit to their school. Since the school is an educational institution and students attend school to become educated, let us examine the fair booth to determine if there are any educational values to be derived from such an activity.

One of the best methods of learning is by "doing." Hence, it is best to learn to *plan* by "planning some activity." In the construction of a fair booth, for example, the students learn the importance of deciding upon goals and objectives. Once that is decided upon, they plan the materials to be used in attaining the goals and objectives established. Such problems as how to design a booth from materials and produce at hand that will tell the

desired story to the public, and is in keeping with established objectives, must be confronted and solved. The detailed planning that must be done by a group, such as keeping within bounds in regard to time, money, materials to construct the booth, and the produce available for display, is of great importance.

Finally, these things must be put together in such a way that the objective is attained and the theme realized. All these things, backed up by the motivating spirit of winning honors for the chapter and school, constitutes a potential for learning that is hard to equal. Certainly, it presents a lesson in imaginative contemplation that surpasses most classroom situations. However, the learning does not stop here. In fact, the objective of such a fair booth is to carry a message of significance to all who view the booth, both young and old, student and nonstudent. The exhibit maintains a learning import as long as it is displayed before the public. The message told by a fair booth often is more effective in influencing the thinking of people than many other teaching procedures.

The fair booth is an excellent medium to use in presenting such concepts as the following: What constitutes good, clean, blemish-free produce? What constitutes good farming practices? What safety measures should be observed and other messages of equal importance to agriculture?

Consider another value of a fair exhibit that so many times is overlooked by educators and the public at large, but yet enters into every exhibit that is worthy of an award. A well-designed fair booth should develop, on the part of students and public alike, an appreciation for aesthetic values. Here is an opportunity to teach the fine art of balance, design, the blending of natural colors and development of beauty from the common agricultural produce found around almost any community. The works of art that are produced in this manner are amazing. The students who design and develop such a work of art are not the only ones benefited. To all those who view such a display of balance and beauty, the sense of appreciation for artistic design is whetted to a finer edge. Who can look upon a well-

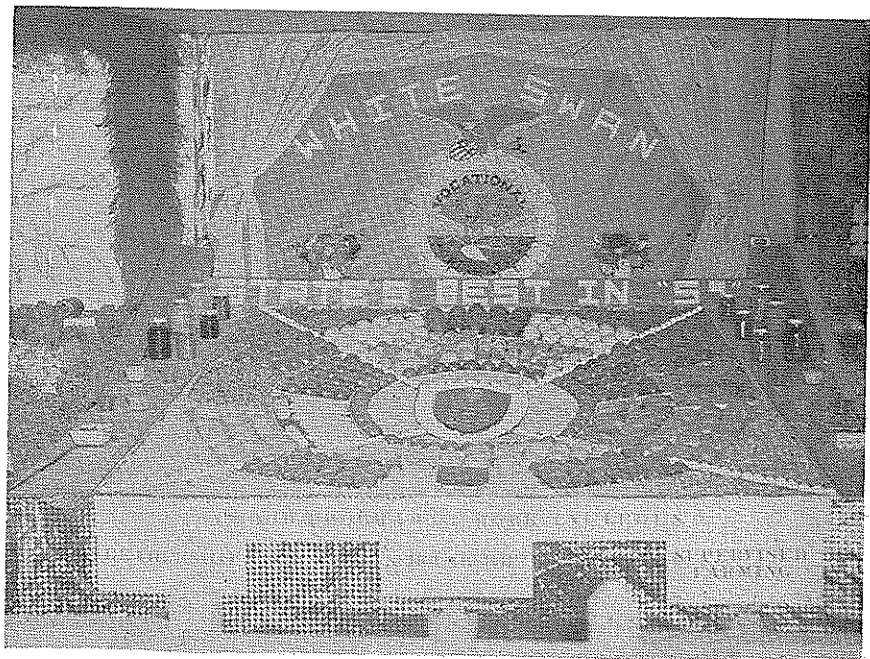

FFA Educational Booth at Yakima, Washington, Fair.

designed booth filled with mounteous produce, bathed in nature's colors blended into one lovely theme, and leave without feeling a spiritual uplift?

In developing a fair booth, still another great lesson is that of working together and sharing responsibility. In other words, this is an opportunity to teach cooperation by *doing*. Responsibilities assigned to *individuals* and carried out together as a *team* constitute lessons all need to review often.

The fair booth often times results in a whole community effort. For example, if the FFA needs produce of a certain kind, chances are that several farmers will be willing to donate all that is needed. Thus, the donor becomes more than an idle by-stander. He becomes an alert participant. Frequently, ideas offered by members of a community can be incorporated into the display to improve its effectiveness. Again, this contributor becomes an interested community worker. The fair booth that started out as an FFA venture sometimes generates community fervor and

pride which often produces an impact of great influence for the good of education in the entire community. Thus, the fair booth becomes a vehicle for encouraging the people of a community to work together and develop pride and interest in their school system.

Finally, perhaps no better "show case" can be found than a beautiful, well-planned fair booth for telling the story of the Future Farmers of America and the public school to the people of a community. People from the locality and neighboring communities come with a receptive attitude, and view with especial pleasure the exhibits on display. Perhaps at no other time in the year will so many people be in such a receptive mood as when viewing a display put up by a school group at a fair. This makes the fair booth a very important piece of work, and certainly the best efforts of the teacher and the students should go into its planning and development.

A well-thought-out fair booth can show a wide variety of FFA activities such as classroom work, the produce

from supervised farming programs, farm shop projects, class projects and related activities. A common fault of exhibits is the display of items that are not in harmony with the theme. It should be axiomatic that when FFA activities are included in the exhibit such material should add to and strengthen the theme and not detract from its balance and beauty.

A good fair booth involves much planning and hard work. Many vocational agriculture instructors are very reluctant to put in the time and effort that are needed to produce the kind of fair booth which will reflect favorably upon the FFA chapter and the school. In such cases, it is best that the vocational agriculture instructor should not attempt to put up a fair booth. On the other hand, it might be revealing to such a vocational agriculture instructor to re-evaluate his year's program of work. If he does a sincere job of budgeting his time in accordance to value received, he may be surprised to learn that the county and state fair booth stands high among the list of priorities! □

Effective On-Farm Instruction of Adult Farmers

ROLF MOECKEL, Teacher Education Project, Central Michigan University



Individual on-farm instruction is a vital part of the adult-farmer program. Classroom instruction, to be functional and vocational in nature, must be based on the farming problems of the farmers. Teachers can obtain considerable information concerning such problems during on-farm visits. As the subject matter pertaining to the problems is being taught, it needs to be adapted to and applied on the farms of the farmers. The teacher has a wonderful opportunity at this stage in the learning process to contribute through individual on-farm instruction.

Procedure of the Study

Due to the importance of on-farm instruction in the adult-farmer program, a study was conducted to identify effective practices being used

by teachers in conducting on-farm instruction.* Briefly, the procedure of the study was as follows:

1. A checklist containing 125 on-farm instruction practices was developed and sent to 138 Michigan teachers of adult-farmer courses for 1957-58. There was a 78.2 per cent response.

2. Meanwhile, the checklist was sent to seventy outstanding teachers of vocational agriculture who had provided outstanding on-farm instruction of adult farmers in thirteen states of

the Central Region, as selected by the respective state supervisors. There was an 80 per cent response from this group.

3. The data from these two groups were compared, and ten promising practices used significantly more by the outstanding teachers were identified for a demonstrational study in 1958-59.

4. Sixty Michigan teachers each performed an average of three and eight-tenths of the promising practices and evaluated the effectiveness of them at the end of the year.

Promising Practices Which Were Studied

The ten promising practices that are referred to in Number 3 above, and which were used in the demon-

*This article is based on a dissertation by Rolf Moeckel, "The Effectiveness of Practices of Individual On-Farm Instruction Used by Teachers of Adult-Farmer Courses in Michigan," Doctor of Education degree, Library, Michigan State University: East Lansing, Michigan, 1960. 201 pp.

strational study during 1958-59, are as follows:

1. Explain the purposes of farm visits during the adult-farmer classes.
2. Maintain a list of potential farm visits to be made to adult farmers.
3. Discuss problems of the farm with the adult farmer and his wife together.
4. Assist the adult farmer to conduct trial plots on his farm.
5. Analyze, with the adult farmer, the instruction of a previous adult class as it is related to his own farm.
6. Take the adult farmer to observe a new practice of another farmer.
7. Analyze the adult farmer's DHIA, soil test, or other farm records.
8. Use local production standards to assist the adult farmer to evaluate his business.
9. Take colored slides or snapshots of approved practices being adopted by the adult farmer to show the "before" and "after" situation.
10. Survey adult farmers during class to determine their viewpoints concerning farm visits.

Implications of the Study

The following implications are based on the results of the study and the beliefs of the investigator. It is believed that more effective on-farm instruction of farmers may be provided if these implications are considered by teachers and applied where appropriate.

1. Individual on-farm instruction of farmers will be more effective if it is closely integrated with instruction given in the classroom, as indicated by the results of this study.

On-farm instruction is usually beneficial prior to, during, and after classroom instruction has been given on a certain subject. A more individualized analysis of classroom instructional information with a farmer having a specific problem usually results in more efficient learning and more desirable change of behavior.

On the other hand, the omission of the classroom instruction and the provision of instruction *only* on the individual basis on the farm usually leaves much to be desired. This is because the farmer may not be given a thorough explanation of the general background of the instructional information from which he could solve similar problems in the future. Neither does he hear class members discuss

their experiences from which he might gain further insight.

During classroom instruction it seems that continual reference might be made as to how this information can be applied on the farm and how the teacher can assist the students on their farms with more specific instruction.

2. Effective individual on-farm instruction of farmers requires that sufficient time be devoted to it.

According to the data from this study, five of the promising practices were selected by a majority or more of the teachers as having the advantage of the farmers learning more, or adopting more farm practices. In other words, the practices were considered effective. However, these same promising practices were selected by significantly fewer teachers than would be expected by chance for the advantage of using the teacher's time economically. Therefore, if the practices are educationally effective but are not considered by the teachers to utilize their time economically, the teacher is not likely to use much practices *unless he is allotted scheduled time*. If the teacher is expected to give this instruction outside of his regular hours of employment without remuneration, the amount of instruction is likely to be inadequate. Teachers who already have a period in their school schedule allotted for on-farm instruction of adult farmers may lose such time unless they rigorously follow the habit of using that time to provide effective on-farm instruction to farmers.

Although not investigated in this study, it is suggested that the school administrator provide assistance in evaluating, with the teacher, the on-farm instruction of adult farmers if it is not now being evaluated. The analysis of detailed monthly mileage reports would be helpful in such an evaluation. Such factors as the number of visits made to farmers, the frequency of these visits, and the type of instruction provided could be a basis for the evaluation.

According to data collected from the Michigan teachers, the average teacher was visiting his students slightly more than twice per year. It has been the experience of the investigator that two visits would barely allow the teacher time to become oriented to the farm program and the problems of the farmer during the various seasons, to say nothing of providing instruction in skills, assisting in planning new practices and

management procedures, analyzing information provided in class meetings, or evaluating new farm practices that have been tried by the farmer.

3. Individual on-farm instruction will be more effective if the farmers understand the general purposes and procedures used during visits.

Although the promising practice relating to this implication was not selected by a majority of the teachers as possessing specific advantages, it is the feeling of the investigator that a brief explanation might be given to the farmers at the beginning of the course, and perhaps periodically as the year progresses, concerning the purposes and procedures of individual on-farm instruction that will be followed. The teacher may wish to explain that visits are made for such purposes as getting acquainted with the farming program, analyzing information presented in class meetings, demonstrating skills that could not be shown in the classroom, and evaluating farm practices that were tried by the farmer. Such general procedures as when the teacher is available for on-farm instruction of farmers, how he can be contacted, and how often he can visit individuals, could be explained. If this type of orientation is provided probably the teacher's on-farm visit time will be more efficiently used, the instruction will be more effective, and the farmers will be more likely to use this educational service.

4. The teaching of specific practices or skills should be provided during most on-farm instruction visits.

Several findings of this study imply that individual on-farm instruction of farmers will be more effective if specific practices or skills are dealt with. Certainly there is a need for farm visits of an exploratory nature in which the teacher becomes acquainted, establishes rapport, and discusses general problems with the farmer. This type of visit should usually be performed at the beginning of a course, especially with a new adult-farmer student. Those teachers who make farm visits only once a year or so are likely to be conducting a rather large percentage of this type of visits. After the initial exploratory visit is conducted, the teacher should usually place emphasis upon the provision of specific instruction while on the farm.

Instruction on specific practices or skills during on-farm visits will require that the teacher make careful

plans with the farmer before the visit, and that he adequately prepare himself for giving the instruction. He might assist the farmer to analyze farm problems so that the need is recognized by the farmer for the actual teaching of a practice or skill. The investigator believes that as this approach to on-farm instruction becomes established, farmers will realize its value and provide even more opportunities through which the teacher may be able to provide individual on-farm instruction in a more effective manner.

5. Teachers could possibly provide more effective individual on-farm instruction on certain subjects by involving the wife, as well as the farmer, during the visit.

The results of the study of the promising practice of discussing problems with the farmer and his wife together, although not having a large number of teachers selecting specific advantages, did bring numerous affirmative remarks from the teachers concerning the value of this practice. Instruction in such areas as records, management problems, and future farm plans is usually of interest to wives. Wives are frequently consulted on such subjects by the farmer in the

teacher's absence. Therefore, unless the wives are involved in the instruction it may not be as effective as the teacher might otherwise expect. Some activities such as record keeping may actually be performed by wives. The provision of instruction in these areas with the participation of the wife is likely to be more effective.

6. The teacher could assist the adult farmer to evaluate farm practices that he has tried or anticipates trying, thus providing more effective on-farm instruction.

This statement has been substantiated by the survey. Outstanding teachers of the region assisted farmers in the evaluating of farm practices during visits to a significantly higher rate than did the Michigan teachers.

The learning process is not complete until the student has evaluated the new farm practice that he has studied or tried, and revised his conclusions. This is especially true in such a complex field of knowledge as that which is encountered by the farmer. Even before the farmer tries a new farm practice he must evaluate experiments of commercial and governmental agencies, experiences of other farmers, and recommendations from various sources. After the farm-

er has attempted a new practice he is again faced with the proposition of whether he should adopt it permanently or on a trial basis, or to reject the idea as unadaptable to his program.

The evaluation of farm practices by the farmer himself must, at times, be a difficult and bewildering task. Conflicting recommendations, varied results of experiments and experiences, and a multitude of factors on his own farm must be carefully considered before a decision is justified. If the farmer arrives at the wrong conclusion concerning the adoption or rejection of a particular farm practice, he may either lose the advantage of the early adoption of a profitable practice or suffer loss from adopting an unprofitable practice. Likewise, if the results of a trial are misinterpreted, causing him to form the wrong conclusion, the farmer is again the loser. The teacher certainly has an excellent opportunity to give effective instruction during this process of evaluating new practices that are being considered or that have been tried by the farmer. Frequently the most suitable place to provide such individualized assistance is on the farm. □



Keep Records of Your Resources

BURL HUNT, Teacher Educator, Kansas State University

Vocational agriculture teachers and their students have established an excellent reputation as record-keepers. Perhaps, part of their success as record-keepers has come about because they have been aware of the values of having certain information available for easy reference.

If the vo-ag teacher wishes to use community resources effectively and improve agricultural classes, a record or guide to community resources should be compiled. Community resources and resource persons should be closely linked to the learning experiences of students.

Often, the most meaningful learning experiences are those which are

gained first-hand. One of the best ways to gain experiences first-hand is to see things for yourself. For the instructor and students, this first-hand knowledge can be obtained through the use of field trips. Properly organized and conducted, field trips have definite advantages for vocational agriculture. When improperly organized, they are a waste of effort, time, and money.

The field trip is sometimes referred to as a school journey, school study trip, directed observation, excursion, or study of community resources. The field trip is one of the oldest techniques used in group teaching, however, it is not used to the extent it

should be. Plato, Socrates, and other ancient philosophers sometimes used the field trip as a teaching-tool.

In modern times the field trip offers even more opportunities to enrich and supplement classroom instruction. Resource persons are available and can be invited into the classroom for the same reason. In addition to enriching and supplementing classroom instruction, field trips and resource persons in the community help the instructor to learn more about the environmental background of the students. Knowledge of this background is essential, especially for the vo-ag teacher, and should bring improved teaching.

In more communities than not,

there is an abundance of free teaching resources and talented resource persons. It seems reasonable to expect educators to be aware of these teaching aids and use them to further the education of the pupils.

If so many resources and resource persons are available to teachers, why are they seldom used? Either teachers do not take advantage of help offered by the local community because they are not aware of the sources of help, or, they do not have a record or guide to the sources of help.

A guide to community resources and resource persons can be made on 4" by 6" cards and indexed according to topic or subject. These cards should give information that would help the instructor select resource persons and places that would add most to the objectives of the lesson.

The information on each card should include:

1. The place to be visited or the name of the person available for classroom visits.
2. A description of what is to be seen or the subject matter area to be covered by a visiting lecturer.
3. The location of the place to be visited.
4. The name of the person to contact in order to make arrangements for the visit.
5. Limit of persons who can take the trip.
6. Time required for the trip.
7. Time the students are permitted to visit or the time the resource person can come to the school.
8. Age group or class that would benefit most.
9. Special information that would be needed by students prior to the visit.

A typical field trip guide card is presented below:

TOPIC: Plants, Landscaping, Soil Samples.

PLACE: Greenville Nursery

DESCRIPTION OF WHAT IS TO TO BE SEEN:

1. Identification of plants, shrubs, and trees.
2. Discussion of landscaping.
3. Soil samples.

LOCATION: R. F. D. 1

CONTACT: Mr. Fred Martin, Phone HI 8-2472.

LIMIT OF PERSONS: Not more than 20.

TIME REQUIRED FOR TRIP: One to two hours.

TIME STUDENTS PERMITTED TO VISIT: By appointment.

AGE GROUP OR CLASS: Vocational agriculture or biology classes.

Educators often overlook the valuable resource people in the community. A guide that includes field trips and other community resources should include resource people. Many of them are willing to come to the school to talk about or discuss things in their area of work. The guide makes it possible for the instructor to select persons who have information related to the subject-matter area being taught in the classroom.

The cards for resource persons might be made up similar to the following sample card.

TOPIC: Animals.

SUBJECT: "Care of Farm Animals."

DESCRIPTION OF LECTURE:

Discussion on care of farm animals and prevention of common diseases of farm animals.

CONTACT: H. M. Greiner, D.V.M.

PHONE: FR 9-2481.

LOCATION: Greiner's Animal Hospital, 6022 West Highway Road.

LIMIT OF PERSONS: No limit.

TIME REQUIRED FOR LECTURE: 50 minutes. (More time required if lecture is followed by discussion or question and answer period.)

AGE GROUP OR CLASS: Vocational agriculture classes.

Since each entry to the resource guide is recorded on cards, it is very easy to revise the guide and bring it up-to-date. A card catalog of resources and resource persons should prove its value by accomplishing the following objectives:

1. Assist teachers in the wise use of time and resources.
2. Make specific planning possible before each field trip or visit by a resource person.
3. Influence teachers to use only the "worthwhile" resources.
4. Help administrators to become aware of the quality of community resources being employed by vo-ag teachers.

There is an additional advantage to field trips and visits from resource persons that make them especially worthwhile for the FFA chapter. They afford an opportunity for the chapter photographer to obtain excellent pictures for the chapter scrapbook. □

Use Local Materials In Teaching

JIMMIE G. LAWRENCE, Vo-Ag Instructor,
Augusta, Arkansas

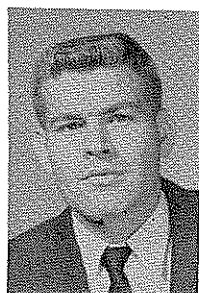

The teacher of vocational agriculture has worlds of materials at his finger tips to help him to do a better job of teaching if he can only find a method whereby he may use them. These methods need not be elaborate or complicated, but detailed enough

to show the student the point which you are trying to convey and at the same time complex enough to offer a challenge.

In farm shop, when you are teaching hardware, show a filmstrip covering various hardware items and give

a lecture concerning the uses of each.

Your next step would be something like this. Take a piece of plywood 3' by 3' and mount several hinges, nails, bolts, hasp, etc. and label each one properly and mount this in your shop.

The next step would be to have the students make a mount similar to the one in shop but on a smaller scale. The student could then take this display home with him and mount it in his farm workshop.

You can apply this method in electrical work concerning different sizes of wires, connections, and insulators and in plumbing with different types of joints.

If you happen to be in an area where forestry is important, you might make a collection of all hard and soft wood in your area and mount each one in a cross, longitudinal, and a transverse section thereby showing the different parts of the tree such as the cortex, cambium, vascular bundles, and so forth, rather than just talking about them in the class room.

You may want to make a display of products which come from the trees such as various kinds of ply board and the different kind of finishes which will look best. When boys have aids before them of this nature, it presents a learning situation which might not otherwise be obtained.

In small engines what could give a boy more understanding about internal combustion engines and their operations than to take a small engine

manual and go through it step by step and get a working knowledge of the principles governing the small engine and then go to the shop and completely disassemble a small engine and put it together again. After a boy has done this, then maladjust some part of the engine and let two or three boys work together to find the trouble and then make proper adjustments.

Several of our states have an area where fruit or nut trees are grown and grafting is a very important thing. A very good and inexpensive way to teach this is to bring lots of willow to the class room and demonstrate the various methods of grafting and then let the student practice. I suggest willow because it is relatively easy to make a graft take and this will help build up confidence in the student. In bud grafting, if you will

take two paring knives and remove the inside handle and put a piece of wood one inch square between them, it will give you lots of cambium tissue and increase the number of "takes" and at the same time give you uniform cuts.

These methods may be old to several of our vocational agriculture teachers, but if they aren't, try them and see what kind of results you obtain. I think you will be amazed at the interest that you can develop by using some simple realistic method of putting your idea across.

Similar activities and materials are available for other areas of instruction also. A little forethought and ingenuity can do much to improve our teaching and to make it both practical and meaningful. □

What About Your Next Exhibit?

W. T. ADAIR, Graduate Assistant, Auburn University, Alabama

Within the next few months many of you will be asked to prepare or assist in preparing some type exhibit. Most likely it will be in connection with agriculture so your major field is already chosen.

Will your next exhibit be traditional or modern? What is meant by these terms? The traditional exhibit is usually one that has a carefully arranged group of local products displayed with some unusually large product in the middle. These usually appear at most community fairs and many times they do not have an educational theme.

The modern exhibit is opposed to this in that it has a theme that is educational. It actually tells the viewer something that will be of importance to him. In order to be of value the modern exhibit has one single idea and everything in the exhibit booth is used to visualize and support this idea. This type requires much work and the use of the imagination but the originator is rewarded if his exhibit attracts attention and the theme is remembered by the viewers.

Basic to the attraction of attention is movement. Movement will attract

attention quicker than any other thing. This is easily achieved by using a common electric fan stripped of its blades as the motor to power a turntable, for instance.

Once you have a person's attention, you must present your information in a brief and precise manner. It is unusual for an individual to spend more than two minutes at any one exhibit especially when several are to be viewed.

The following audio-visual aids may be used in an exhibit to assist in presenting your idea. Probably the most basic is a mural painted or printed on the background or backdrop of the exhibit booth. Pictures and written material may be used here to explain the exhibit and list any recommendations.

Translite film is very effective when used with exhibits. These are better if they are locally made and tell something of the local community. Tinting adds to the effectiveness. Multiple diffused light boxes may be made in the local farm mechanics shop and present several views in one box. Translites are effective when used by

themselves in any public display as well as with exhibits.

Continuous movies add to the movement of the exhibit and also help to tell the story. This may be accomplished by using an on-the-spot operator. A more effective way is to use a continuous loop of film. This is easily done since the time should be limited to two or three minutes. Color and sound add to the effectiveness of the film.

Another way to tell your story with pictures is by using continuous slides. This can be done in several ways. Probably the best way is the use of the Tel-A-Story projector or some similar machine since it is automatic and has its own built-in screen. If a machine of this type is not available, an automatic slide projector may be used or a manual projector with an on-the-spot operator.

The following is a list of suggestions or ideas in preparing your exhibit and making it look realistic:

1. Grass may be made from dyed Turkish toweling or dyed sawdust dropped on a glued surface.
2. Evergreen trees may be made from painted steel wool in layers and using clothes hanger wire for a trunk.
3. Small evergreens may be made by shaping green rubber sponges.
4. A spotlight added at an angle gives effective shadows. □

Suggested Teaching Procedures for

Farm and Home Planning

IRVING C. CROSS, Teacher Education, Fort Collins, Colorado



Most individuals have rather definite ideas as to what they want out of life. Ideas may vary in some respects but basically most people strive to attain a better standard of living. If, as an individual, one is to succeed in improving his standard of living, he will need help and assistance in planning for the management of his resources. The farmer finds himself in this same situation and it would seem that the local vocational agriculture teacher is a logical person to give long time systematic instruction to the farmer in improving his present farming situation and developing plans to help him reach the goal of better living on the farm. This might well be done through the framework of young and adult farmer courses in Farm and Home Planning, utilizing resource persons and material such as the Soil Conservation Service and the Farmer's Home Administration. Farm records and accounts from the individual farmer will also be necessary.

A plan and procedure for conducting such young and adult farmer courses was developed by the Agricultural Education Section of the Department of Vocational Education at Colorado State University in 1959. After three years of experience with such courses being conducted in local vocational agriculture departments, the following suggested procedure has evolved:

1. The first step in Farm and Home Planning is taking an inventory of the resources available to each of the class members. The three basic resources available to the farmer are land, labor, and capital. When the farmer knows the amount of each resource that is available to him, he has the tools upon which all future planning may be based.

2. After an inventory of the three main resources referred to above is completed, the next step will be for each farmer to take a more detailed look at the actual capability of his land. With the help of the Soil Conservation Service and its resource

material, each farmer in the class will obtain a picture of what his fields or areas of his farm are capable of producing. This step also gives the farmer an idea of what crops he can raise within the limits of good conservation practices. Some class activities would be a study of land classes, the reading of soil maps and aerial photographs, the preparation of soil map overlays, and taking soil samples and interpreting results.

3. The next step deals with the laying out of fields and rearranging the farmstead. Each class member will draw up a proposed field layout, taking into consideration the conservation of the soil, decreasing the labor requirements, improving the land and other factors which will help to make his field layout more efficient.

4. An efficient crop rotation system is necessary to maintain the fertility and productivity of a farm. The next step deals with each farmer planning a crop rotation system that will fit into his present farming program and which can be changed or modified to fit into his proposed long time plan. To accomplish this task each farmer must consider the capability of his land, requirements for livestock feed, cash grain, and other factors which affect the amount and types of crops to raise in order to realize maximum production from the farm.

5. While each farmer is planning a cropping system he must keep in mind the balance between the crops produced and the feed that the livestock on the farm will consume. In most instances the most efficient way to market crops is through livestock. The purpose of this step is to insure that the cropping system and the plan for the number and kind of livestock are kept in balance so that the farmer will not have excessive surplus feed on hand or find it necessary to buy feed at high prices.

6. The next step is setting the long time goals for developing the farm home and the family. As this step involves the farm wife as much as or

more than the farmer, both will be brought into the class to work as a team in completing the planning of this phase. Goals will be set in terms of recreation, home improvements, clothing, furnishings, health, education, insurance, savings, and any other needs of the farm home and family. The farming unit must provide for these needs if the farmer and his family are to have the standard of living they desire.

7. With the facts, ideas, and principles given in the preceding steps, the farmer is now ready to compile them into a long time farm plan which will picture what his ambitions and goals are for the next five years. He charts his farm improvements, home improvements, and family expenses, balances his projected crop and livestock programs, and checks his anticipated working capital against proposed machinery and other capital expenses. This is a total farm and home projected annual plan, a look into the future, and a charting of his course.

8. Budgeting is very important to the success of any operation. One of the most important steps in farm and home planning is to have each farmer prepare a budget as a tool for evaluating his proposed plans. By preparing a budget of proposed monthly income and expenses he calculates the amount of capital needed and available to meet the necessary farm and home expenditures. The farmer will need to compute his monthly labor requirements to see if his proposed plans can be handled by the farm family or if additional labor will be required. This will be necessary in order to arrive at the labor expense for the budget.

9. The final step in farm and home planning is to have each class member compile an annual farm and home plan. This annual plan represents the first step in reaching for the goals established in the long time farm and home plan. Using the budget as a tool for control of his farm business

An Example of—

Professional Improvement on the Local Level

ELMER L. COOPER, Teacher of Agriculture,
Pylesville, Maryland



If we were asked the simple question, "How can a farmer best prepare for future success and professional survival?" we would probably scratch our chins awhile and finally say something like this—"To insure future success, a farmer must keep abreast of latest developments and apply those practices which make for the most efficient operation." Of course, new developments may come from a neighbor, a distant farmer, a college or U. S. D. A. scientist, or from other agriculture agencies. For teachers of agriculture, the key to a successful program and to professional growth is obviously the same as for the farmer.

To become aware of these developments and to study effective practices in our field, a group of teachers from Harford and Cecil counties devoted several days of last summer's program to visiting the agriculture departments of some successful Maryland teachers. Both agriculture teachers from our own school were anxious to participate in the project. When we approached our high school principal, we found that he not only sanctioned the use of summer time, but offered to help with some expenses and planned to take the trip with us. Unfortunately, last minute developments prevented his going along. Our State Supervisor highly endorsed the plan also, and offered more time than we had planned for the activity.

Since Harford and Cecil counties are located in the Central Maryland Piedmont area, we naturally wanted to see programs of vocational agriculture in livestock, dairy and general farm areas. We chose to visit departments that we thought would offer the most original ideas, applicable to community needs similar to ours. Since our department at North Harford School has a rather extensive school farm, we naturally wanted to see how other school farms in the state are run. We wanted especially

to see multi-teacher departments, outstanding shop facilities, and effective FFA programs. In pre-planning the trip, we set up the following list of areas for considerable observation:

- I. Enrollments
 - A. Total
 - B. By classes
 - C. Adults
- II. Teaching Schedules
- III. Farm Shop
 - A. Teaching techniques
 - B. Procedures (start class, clean up, teaching, etc.)
 - C. Projects
 - D. Storage
 - E. Hand tools
 - F. Power tools
- IV. Teaching Units by Classes
- V. Books, Bulletins and Other References
- VI. Teaching Aids
 - A. Unique aids
 - B. Films
 - C. Charts
 - D. Organization and storage
- VII. FFA
 - A. Program of work
 - B. Unique activities
 - C. Money-making activities
- VIII. School Farm
 - A. Facilities
 - B. Use in teaching program
 - C. Labor
 - D. Special problems

After careful consideration, we decided to visit no more than two departments per day. We planned a two-day tour and made plans with the teachers of four different schools to meet with us at a certain pre-planned time. Our careful planning paid large dividends in that there was little time lost in making contacts with the teachers in the various schools—they were waiting when we got there in most cases. Along with the four planned schools, we were able to look at the facilities of two additional schools which we passed on the way.

Once we were in a department and had started discussing the program with the teacher, we found that ideas and procedures began to "swap." The teachers seemed pleased to have us view their setups and hear their ideas as well as to learn some of the things we do in our schools. The experience was invaluable as far as I am concerned. I find many times as I ponder over a thought or idea, I recall that so and so does that a certain way, or perhaps I recall a certain feature in some shop that we should adopt in ours, or maybe I "go slow" on something because I recall a teacher who had a rather unpleasant experience in a similar situation.

There is one thing certain; we cannot use the agriculture program from one community as a blueprint for another area. However, there are many practices which can be used in a variety of locations. As I think back over my summer program for the last year, the two days spent visiting other departments come to mind first. From the standpoint of professional growth, I know of no better activity. One bit of advice if you try such a venture—travel in a large enough group to promote good discussions, and encourage your principal or supervisor to go along. You not only see someone else's triumphs but you also learn of their tribulations—in case "the grass sometimes looks greener on the other side of the fence." □

Farm and Home Planning—(continued)

he can make adjustments on his proposed plan and come up with the yearly plan which will prove most efficient to the farm.

If farmers are led through this farm and home planning program and they develop the annual and long time plans based on the facts, ideas, and principles discovered, they will have the controls of their operation within their grasp. They will picture their goals in a realistic manner and will have the first leg of their journey to their goals well charted and planned. They will also be anxious to continue the young or adult farmer classes from year to year in order to gain knowledge and skills in implementing the plan and make the necessary revisions in their annual and long time plans. They will thus make much faster and more efficient progress towards realizing the standard of living they have set as their goal. □

New Address for NVATA



James Wall has been appointed full-time Executive Secretary for the National Vocational Agriculture Teachers Association. According to F. D. Johnson, President of NVATA, Mr. Wall took up

his duties as full time Executive Secretary at Lincoln, Nebraska, on July 1, 1961. The new address for the national office is:

Mr. James Wall
Executive Secretary, NVATA
Box 4498
Lincoln 4, Nebraska

Mr. Wall has served as Executive Secretary for the past few years on a part-time basis. Due to action taken at the National Convention last December, the executive committee of the NVATA was able to make the office a full-time appointment.

TIPS THAT WORK

Proper Dress and Appearance for Boys in Vo-Ag



I am introducing a new subject to my vocational agriculture boys this year. I call this subject *Proper Dress and Appearance*.

I plan to teach proper color combinations with cut-outs of cloth.

I will use a flannel board and place the pieces of clothing on it to show proper and improper clothing colors, ones which do and do not go together. Shoes will come under this part of the subject, also.

The next part of the subject is cleanliness. This will cover the hands, fingernails, face, and information about the rest of the body. The

third part has to do with haircuts. Most of this information will come from a barber and will involve such decisions as how often should you get a haircut, and what style of haircut looks best on a teen-age boy. The fourth part covers proper dress for trips, such as field trips, judging trips, banquets, and conventions.

The fifth and last part of this subject covers several things. First is manners; second is proper behavior; third is proper use of English. The point will be made that if we practice all three of these, we will become better citizens.

I will use colored slides and short skits to help put the subject as a whole across to the students. The persons involved will be the students, the instructor, and resource people invited to participate in a specific area.

I believe this subject will be very interesting as well as educational for the students. I know the boys of the Burley High School are all in favor of this subject. □

Charles Clark
Vo-Ag Instructor
Burley, Idaho



SOME PRINCIPLES AND PRACTICES OF FARMER COOPERATIVES by H. M. Olsen. Published by The Interstate Printers and Publishers, Inc., Danville, Illinois, 118 pp. 1961. Price \$1.25.

The writer has condensed some of the published materials on farmer cooperatives for the convenience of instructors of vocational agriculture and other interested in studying about farmer cooperatives. This manual will also serve students who are studying cooperatives as a way of doing farm business.

The manual is clearly written, concise, and well-organized. It deals briefly with most phases of farmer cooperatives including purposes, basic principles, types, benefits, member responsibilities, success factors, financing, taxes, laws, relations with other groups, and future trends.

The publication is divided into 20 sections. Each section contains three parts: (a) statements or topics to be used in

introducing the study of a specific phase of the cooperative way of doing business, (b) explanatory statements on items listed for the section, (c) follow-up and study questions. It contains a glossary of terms and a list of aids on farmer cooperatives.

Mr. Olsen is Executive Secretary of the Washington State Council of Farmer Cooperatives, Seattle, Washington.

Robert L. Hayward
State Department of Education
Missouri

FARM BUILDING DESIGN by Loren W. Neubauer and Harry B. Walker. Published by Prentice-Hall, Inc., Englewood Cliffs, N. J., 611 pp., illustrated. 1961. Price \$9.00.

This is a new book on the fundamentals of farm building design. It gives a very functional coverage of the design of farm buildings including farm houses, barns, sheds, shades, storages, grain bins, silos, animal shelters, water supply facilities, and septic tanks. The authors indicate in the preface that the book was written as a result of their teaching and research at colleges in the Midwest. It's designed for universal application and not for any particular region.

The text gives a good discussion of building layout and design. It is well

illustrated with photographs, tables, graphs, and drawings. Also, it is well organized and interesting and easy reading. The depth of treatment and suggested laboratory problems at the end of each chapter should be helpful to the student seriously interested in farm building design.

There are 29 chapters, and the book is divided into two parts. Part I deals with the structural types and designs while Part II pertains to materials and structural designs. The book is written on the level of the college student, however, it is well adapted to the use of teachers of vocational agriculture.

Mr. Neubauer is Professor of Agricultural Engineering at the University of California.

H. D. Brum
Assistant State Supervisor
Vocational Agriculture
Ohio

Disraeli—The more extensive a man's knowledge of what has been done, the greater will be his power of knowing what to do.

Stories In Pictures



Farming on the rolling plains of Kansas requires a knowledge of surveying. In the photo student teacher Ted Samuelson, senior in Agricultural Education at Kansas State University, instructs a class of sophomore boys in vocational agriculture on the problem of figuring land slope.

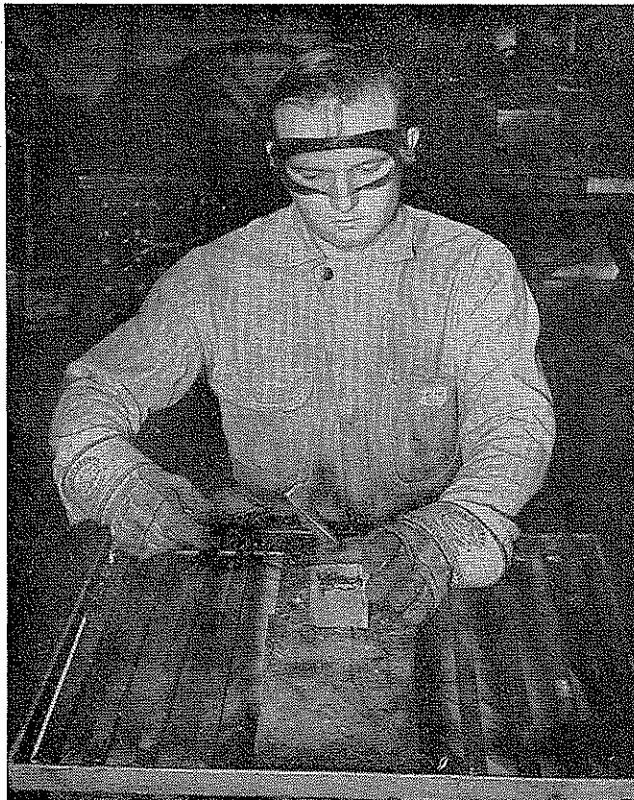

Eyes are our most priceless possession. Clear vision eye shields protect against flying slag or chips. Loren Whitmore, teacher of vocational agriculture at Otis, Colorado, demonstrates the use of clear vision eye shields in this operative step following arc welding.

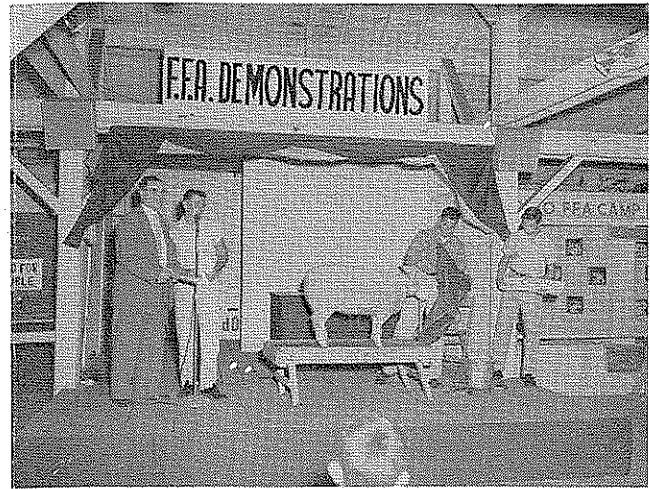

Vocational agriculture students learn a great deal by giving demonstrations for viewers at various fairs and livestock shows.

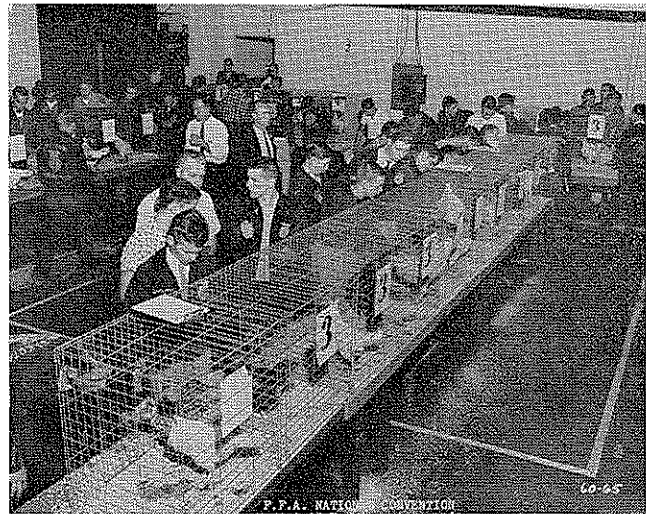

These boys will know better how to judge poultry by having experience in the field. The picture was taken at the National FFA Convention, 1960.

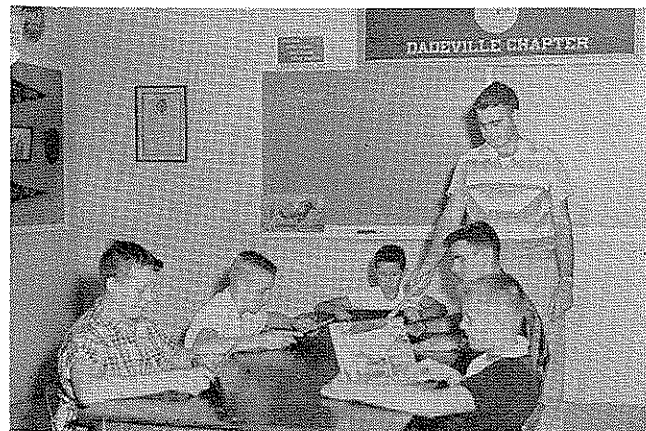

Oscar Strickland, teacher of Vocational Agriculture, Dadeville, Alabama, uses pictures quite often in his teaching. In the above photo he has one section of his 9th grade class studying desirable type in dairy cattle. Following classroom study he and the class will go on a field trip to see the breeds of animals first hand.