

Agricultural Education

SEPTEMBER 1964



Featuring—Vocational Agriculture in Urban Schools

The professional journal of Agricultural Education. A monthly, managed by an editorial board chosen by the Agricultural Section of the American Vocational Association and published at cost by Interstate Printers and Publishers, Danville, Illinois.

THE INTERSTATE  DANVILLE, ILL.

The Agricultural Education Magazine

MANAGING EDITORS

Ralph J. Woodin, Ohio State University, Columbus, Ohio, Editor 43210
 A. H. Krebs, University of Illinois, Urbana, Illinois, Consulting Editor
 T. L. Faulkner, Department of Education, Montgomery, Alabama, Business Manager

SPECIAL EDITORS

CENTRAL

John Coster, Purdue University, Lafayette, Indiana
 M. G. McCreight, University of Nebraska, Lincoln, Nebraska

NORTH ATLANTIC

Gene M. Love, Pennsylvania State University, University Park, Penn.
 Jesse A. Taff, State Department of Education, Boston, Mass.

PACIFIC

Orville Thompson, University of California, Davis, California
 Howard Christensen, University of Nevada, Reno, Nevada

SOUTHERN

Byrle Killian, State Board of Vocational Education, Stillwater, Oklahoma
 J. A. White, Auburn, Alabama
 C. C. Scarborough, North Carolina State College, Raleigh, North Carolina

AT LARGE

Robert Howey, Sycamore, Illinois, Teachers
 Ray Clark, Michigan State University, East Lansing, Michigan, Book Reviews
 H. N. Hunsicker, U. S. Office of Education, Washington, D. C., Vocational Division
 Earl T. Carpenter, University of Missouri, Columbia, Missouri, Research

SPECIAL REPRESENTATIVES

North Atlantic, David McClay, The Pennsylvania State University, University Park, Penn.
 Central, R. J. Agan, Manhattan, Kansas
 Pacific, Orville Thompson, University of California, Davis, California
 Southern, George Hurt, Texas
 N.V.A.T.A., W. S. Weaver, Delphi, Indiana

EDITING-MANAGING BOARD

R. J. Agan, Kansas, Chairman; Orville Thompson, California; George Hurt, Texas; David R. McClay, Pennsylvania; W. L. Bomeli, Michigan; A. W. Tenney, Washington, D. C.; R. W. Montgomery, Alabama; W. S. Weaver, Indiana; T. L. Faulkner, Alabama; A. H. Krebs, Illinois; Ralph J. Woodin, Ohio.

Subscription price, \$3.00 per year, payable at the office of the Interstate Printers and Publishers, 19-27 N. Jackson St., Danville, Illinois. Foreign subscriptions, \$3.25. Single copies, 35 cents. In submitting subscriptions, designate by appropriate symbols new subscribers, renewals and changes in address. Articles and pictures should be sent to appropriate Special Editors or to the Editor. No advertising is accepted. Second-class postage paid at Danville, Illinois.

Volume 37

September 1964

Number 3

IN THIS ISSUE

EDITORIALS

Guest Editorial	59
David R. McClay	
From the Editor's Desk	59

ARTICLES

We Adjusted Our Program to Urbanization.....	62
Robert A. Kopf	
If You Add Horticulture.....	64
John C. Walter	
Training Future Teachers in Forestry.....	65
Luther R. Hiltbrand	
More Inductive Teaching Needed.....	66
S. S. Sutherland	
Barriers to Good Relationships.....	67
J. C. Atherton	
Horticulture and Forestry.....	68
Anthony Juestrick	
There's a Place for Teaching Landscape Design.....	69
Edward C. Dippold	
A Greenhouse in Your School.....	70
Joel Pynch	
Iowa Vo-Ag Department Campaigns for Safe Corn Harvest.....	72
R. E. Hauptmann	
Studies in Progress in Agricultural Education.....	73
Glenn Z. Stevens	
Now Here's an Idea.....	78
Don W. Brock	

DEPARTMENTS

Letters to the Editor.....	60
News and Views of the Profession.....	79
NVATA News	79
Stories in Pictures.....	80

The Cover

Greenhouse, Gleditsia Ginkgo and girls—all new terms to vocational agriculture are a part of the vocabulary of teachers in urban high schools. This picture shows Peter Wotowiec with 2 members of his vocational horticulture class at West Technical High School in Cleveland, Ohio, where this program prepares big city boys and girls for employment in a growing segment of agriculture. Vincent Feck, the other member of this 2 teacher team, took the picture.

Want to help improve this magazine? Send us your suggestions in our reader survey.

Editorials

From the Editor's Desk . . .

No Bed of Roses



Ralph J. Woodin

Most vocational agriculture programs in the past have been offered in rural high schools. Such programs are a part of a few large suburban high schools where the suburbs have enveloped former rural communities, but are included in the curricula of only a few of the big city high schools of the nation. In spite of some talk on our part, little progress appears to have

been made within the last decade in developing new vo ag programs in large city schools.

There are good reasons why vocational agriculture should be offered by some large city schools. In many cities there is the menace of rapidly growing slum areas filled with potential dynamite for the entire social system. The city's educational system is usually looked upon as the best means of coping with this problem and of improving the next generation's citizenry.

A big city school administration in discussing the problem recently put it this way, "The problem of our youngsters who graduate or who quit school, is one of finding a satisfactory first job within six months after leaving school. If they don't find that job, you will find them in trouble with their parents, their institutions and with the law in a very short time. Our school has to help make them employable before they leave."

This is where vocational education comes into the picture—perhaps a different type of vocational education than has been previously offered. Agricultural education has a place in occupational training—particularly for the disadvantaged student. There are opportunities for these students to find employment as horticultural and park workers, as greenskeepers, as food and produce handlers. Agriculture can tap an inherent interest which some of these students have as a result of family background or natural bent. Agriculture can be a useful vocational offering if the city has suitable employment opportunities which require

agricultural training and if student interest in such careers can be developed.

Developing such a program of vocational agriculture in an urban center, calls for many changes in the traditional program. As we have observed a few successful programs, certain adjustments seem to be necessary. Here are some of them.

- Student numbers need to be small enough that considerable individual teaching and supervision can be given. Probably 25 students per teacher would represent an optimum enrollment of high school students.
- The school must take a greater responsibility in providing occupational experience. Greenhouses, cold frames, garden areas, land laboratories and similar facilities must be provided.
- The educational program must reach students who are potential dropouts before they leave school.
- Training must be given for the specific employment opportunities which are available for the students who are enrolled.
- Placement and follow-up of students on the job becomes more essential.
- Special teaching methods, including more individual instruction, become necessary because of the limited capabilities of some of the students who are enrolled.
- Creativity and ingenuity, on the part of the teacher, become especially important in dealing with the problems of securing appropriate facilities and in carrying out a new and different program.

Vocational Agriculture in the large urban school offers no bed of roses to the teacher. It does offer a chance to be of real service to some of the people in our nation who are most in need of an education for the world or work. If we approach big city school administrators with a program which will prepare some of their problem students for employment, we may have an opportunity to serve where our services are greatly needed. □

Ralph J. Woodin

Our Future in the Urban School

Guest Editorial . . . DAVID R. McCLAY, Teacher Education, The Pennsylvania State University



David R. McClay

Vocational education in agriculture needs to expand in at least two frontiers—in adult education and in urban schools. Some of the same forces are responsible for change in both dimensions. Specialization required by a mechanized agriculture increases pressure for more adult education programs.

Interestingly enough, this specialization and resulting increased

production has evicted farm people and initiated migration of the labor force away from production agriculture. A half century ago, one out of three people lived on a farm; less than one in every ten lives there today.

This relocation of our population has changed people's interests and attitudes. People have become reorientated from production agriculture to those aspects which have a more direct bearing on their life.

Interpreters for Agriculture

Sales and service represent a growing segment of our national economy. This may be expected with a rising standard of living. But it has implications for vocational agriculture. As the masses of people become farther removed from production agriculture, more and more individuals are needed to interpret and to perform important agricultural functions in society. Many of these needs may be categorized as part of agricultural sales and services. When one adds these sales and service workers to producers then almost forty per cent of our nation's work force is engaged in the production, marketing, or distribution of agricultural commodities.

Vocational education programs are needed in urban schools which will equip young men and women with knowledge and skills in agriculture required for certain important careers common to urban and suburban areas. Vocational education programs in ornamental nursery work, turf management for parks and golf courses, greenhouse work, grounds and estate management and services, garden store management, landscape contractors, flower store management, growing vegetables and small fruits for market, and similar areas represent likely directions for vocational agriculture in urban schools.

Agriculture for Everyone

As homeowners, city dwellers need to know enough about agriculture to be able to select animal pets or the variety of shade tree which will give them the greatest pleasure. Perhaps even the tensions and frustrations of city traffic or a long day at the office may be relieved through avocational horticultural interests. Consumer education in the selection of food should be a part of every person's education. A general agriculture course, primarily exploratory in nature, taught in elementary or secondary schools would be a step in the right direction. Avocational and consumer adult courses in agriculture should be encouraged.

Agriculture may also be used as a vehicle for demonstrating physical and biological principles. One of the most insightful ways to teach is with examples and experiments. California has taken the lead in developing instructional aids for teachers of agriculture which emphasize scientific principles in biology. Chemistry, physics and mathematics hold prom-

ise for similar development. This type of course content is appropriate for urban schools.

Future Facilities

During the 1959 A.V.A. Convention, the agriculture group I attended was taken on a bus tour to observe first-hand several agricultural programs in junior and senior high schools of Los Angeles. We observed excellent horticultural programs in several junior high schools. In the city of Van Nuys, near Los Angeles in the San Fernando Valley, we visited a multi-teacher vocational agriculture department. In addition to extensive horticultural facilities, we inspected the schools' facilities for offering instruction in crop and livestock production. The land and buildings for livestock and crop instruction were confined to a few acres within the city. Students enrolled in the agricultural area of their choice and obtained practical experience through their projects or farming programs conducted at the school or by cooperative work experience on nearby farms or ranches. Schools in numerous other cities of the nation have had excellent urban agricultural programs for years. I am familiar with programs in Camden, New Jersey, Philadelphia, New York City, and Cleveland.

Future urban agricultural facilities will differ considerably from the traditional farm-orientated programs. Greenhouses, nurseries of ornamental trees and shrubs, and experimental turf plots will be listed as "must" agricultural school facilities. Interest in exploratory agriculture may require facilities more nearly like an instructional classroom. Laboratories educating students for agricultural business occupations may be used jointly

by several vocational services including distributive education, business education, and others.

New Legislation

In general, we can expect to see greater cooperation among the branches of vocational education. A good reason for this is the 1963 Vocational Education Act (P. L. 88-210). It encourages close coordination within vocational education to produce a person with skills in many areas. Opportunity awaits agricultural educators who can accurately forecast future needs and initiate programs to meet them.

One role of leaders in agricultural education is the implementation of P. L. 88-210. In addition to improving and modernizing present programs, school administrators in metropolitan areas should be informed of the kinds of occupational education which now can be offered through vocational and technical agricultural programs. Financial support for new and existing agricultural classes will be forthcoming from P. L. 88-210 appropriations. A campaign of personal visits, printed brochures, and extensive use of the press, radio and television will be necessary to sell new programs to school administrators and the public.

We have an inspiring task: the education of youth for occupations in agriculture. Vocational education in agriculture resulting in efficiencies in production, marketing and distribution, represents a means of maintaining a high standard of living in face of the population explosion. Many profitable and financially attractive career opportunities in agriculture continue for both the rural and urban youth. □

L E T T E R S

Sir:

Regarding a change in the name of FFA. I have studied this problem for some time and in all fairness to the thousands of young men in this country who will continue to serve agriculture as farmers and ranchers I have no choice but to recommend that we continue to develop the FFA program, basically, around the boys who now are or wish to become engaged in the business of commercial farming or ranching. I believe this is their birthright. I recognize that this direction will not result in an expanding program of numbers of people. However, it could become an expanding program of service to an ever increas-

ingly important segment of society.

In past years, we have helped give tremendous impetus to the changes resulting in higher standards of living for rural people. The phenomenal change that has taken place does not show to advantage because the improved practices in farming and ranching have benefited our total society as much and in many instances more than they have rural people. Even so, the change has come about because of efficiencies in farming and ranching, not because of the so called related agricultural occupations.

I should hasten to point out that many of my staff and colleagues do not agree with me and would recommend that we

change the FFA name and objectives to include boys and girls interested in any agricultural occupation. This, they feel, will give us an expanding program of numbers of people and with this larger clientel should go greater prestige and greater funds. I am sure they are right about the greater funds but I cannot agree that this direction will result in greater prestige. I, for one, am not willing to kill the goose that lays the golden egg in order to enjoy one egg for a short time.

On the other hand, I hope you will not get the idea that I am old fashioned and opposed to change. I believe the new vocational education act will give a tremendous boost to our educational program of service to agriculture and I wholeheartedly welcome the opportunity to expand into agricultural occupations other than farming. We, of course, as many others, have been doing this in part for years but not to the extent that we should.

Consequently, my position is one of keeping and enhancing our heritage of farming and ranching for those interested in farming and ranching and, at the same time, develop another youth organization for those interested in nonfarming agricultural occupations. This would enable both groups to develop to their greatest capacities.

HAROLD B. TAYLOR
State Supervisor
Indiana

Sir:

Mr. Cecil E. Stanley has discussed an important, timely subject, Coordination of Vocational Agriculture with Other Vocational Programs.

The discussion is essentially controlled or circumscribed by the three questions raised by the editor. The importance of coordination and some of the background to the problem of developing cooperative effort in vocational education has been emphasized clearly in this article.

The article has stimulated me to add this comment, "that coordination is secured by an improved attitude toward cooperating of the various services." This attitude can be improved by actually developing inter-relationship programs from various services as outlined by the Vocational Education Act of 1963. This will create the situations for more coordination between services in vocational education.

The article further emphasizes the need to continue the basic program of vocational agricultural education for farming. However, now agriculture is more than farming. Our challenge is to broaden the program to include other agricultural occupations. Let's not overplay the sacredness of the program of the past so as to dim our focus on what is ahead of us now and in the future. The emphasis placed on the out-of-school instruction for young farmers and adult-farmer education is a good possibility. I want to call attention to the great possibility of development of young farmer and adult-farmer education through area school programs whether on a county or large community area basis. In this kind of an administrative development, specialists needed in agriculture for young and adult farmers will be able to be provided.

It is my opinion the Vocational Act of 1963 with its emphasis on out-of-school programs will create conditions very favorable to expansion and development of young and adult farmer education.

HARRY E. NESMAN, Chief
Agricultural Education
Michigan

Sir:

I would like to commend Mr. Stanley for his thought-provoking article on coordination among vocational services. One of the underlying philosophies expressed in the National Vocational Education Act of 1963 is the emphasis upon quality vocational education for all, irrespective of age or *place of residence*.

To me, this means that rural residents should have the opportunity to prepare for distributive occupations, for example, and that distributive education should be available to supplement vocational agriculture offerings. Similarly, it should mean that city and urban students should have access to vocational education in agriculture and that it should be available to supplement distributive education instruction, for example, in a number of the occupations which transcend both services. While Mr. Stanley may have been unduly restricted by the editor's questions, it would seem that he could and should have gone further by pointing out the desirability of providing agricultural education in (largely city) schools where only distributive education now exists.

It seems self-evident that in a number of occupational areas, joint contributions by two or more of the vocational services will be needed. This cooperation should not be limited to rural schools but should include both rural and urban schools.

ROBERT E. TAYLOR
Director

Sir:

I was very pleased to see the article, "Four Steps for Pilot Programs," by Joe R. Clary in *The Agricultural Education Magazine*. A major weakness of vocational education in Agriculture has been the limited amount of effort that has been expended in pilot programs. Perhaps this article will promote increased interest in pilot programs in vocational agriculture.

We need to try in a systematic, controlled way many new programs and procedures. The need for pilot programs is especially acute as a result of the Vocational Education Act of 1963. I was especially pleased to note that the article outlined the four steps or stages of pilot programs. These four steps or stages are often ignored. The result is a pilot program that is inadequately defined, organized and conducted.

It has been my observation that teachers, administrators, teacher educators and supervisors do not distinguish between steps 3 and 4. An attempt is often made to disseminate information about results of pilot programs during step 3, evaluating through field testing. This often ruins a pilot program and may lead to the dissemination of ideas that are not successful or worthwhile.

I hope that we can have other articles in *The Agricultural Education Magazine*

pertaining to the organization, conduct and evaluation of pilot programs.

LLOYD J. PHIPPS
Teacher Education
University of Illinois

Sir:

I should like to comment on the editorial by Mr. John Bunten in the July, 1964 issue of *Agricultural Education*, entitled "Our Place in Vocational Education."

It would seem that we have not yet fully recognized or accepted our responsibilities in meeting future needs in agricultural training. Most of us would feel that we have done an acceptable job in the past and some would still settle for continuing only that program, leaving to others the expanded concepts for education in agriculture.

The area vocational school, at first glance, seems to be the best single technique or procedure for providing intensive training in new programs for off-farm, agriculture based occupations. Our big problem will be in providing such schools in geographical areas near our rural youth. The past experience of providing these only in larger population centers is likely to work hardships for youth in more sparsely populated areas. In other words, it will continue to be difficult to provide adequate programs in many of our rural areas.

As Mr. Bunten so well says, the vocational agriculture teacher may continue to be the only one, or one of a very few, vocationally trained or oriented members of the rural high school. Can we then provide expanded programs of real vocational value in such geographic areas? We must use our imagination and ingenuity, and cooperate between services to a degree not yet done, in order to provide programs which will be adequate.

MARVIN D. THOMPSON
Head, Agricultural Education
Wisconsin State University—River Falls

Sir:

The new Vocational Agriculture program outlined in *The Agricultural Education Magazine* for North Carolina by Mr. Bullard should prove very beneficial for training youth in industrial areas. Many would be provided with training that would result in profitable employment.

However, it would be a serious mistake to suddenly change the entire picture of vocational agriculture as many rural areas need the traditional program. We should be cautious that the new type of training is not fragmented and lacking in depth.

Vocational Agriculture has developed a desirable image in America and become highly respected primarily, because of:

1. A leadership program unexcelled for development of our youth.
2. The training in management so that students acquire an understanding in relationship of various entities in a total program.

This type of program has appeal to superior students whose eventual leadership and abilities has placed them in places of influence. This has brought support for vocational agriculture.

The present program of vocational
(Continued on page 63)



Robert A. Kopf

What happens to Vocational Agriculture in a community forty miles from New York City which has been an agricultural center but which now finds itself caught in the current of

urbanization? With three high schools enrolling 2,300 students and with projected enrollments of 4,500, what should the course of study be?

Here is the story of what has happened and is happening to Freehold Regional High School.

Freehold Regional High School is situated in a county seat of Central New Jersey. It has had an Agriculture Department since 1914. The population of Freehold is 9,000. It has a rich tradition of Americana going back to pre-Revolutionary days. Traditionally, this community, located only forty miles from New York City, has been the center for extensive truck, poultry, and dairy farming. The population explosion, the expansion of suburbia and parkway facilities have changed the picture considerably. Freehold serves eight rural and recently suburbanized municipalities covering 198 square miles. Recent surveys indicate the possibility of near complete urbanization within the next twenty or thirty years.

There have been two major expansions in Freehold Regional High School during the past fifteen years. Additional classroom and school facilities with a capacity for 1,500 soon became overcrowded and double sessions were initiated to accommodate the 2,300 students enrolled. A second high school was built and occupied in September, 1964. A third high school is being planned for 1970 with a total projected enrollment of 4,500 students in the three schools which make up this comprehensive system.

Differing Career Choices

At the present time, there is a need for instruction for those desiring to pursue farming on either a full or part-time basis. Urban development necessitates more concentrated instruction in ornamental horticulture, greenhouse products, landscape maintenance and related subjects. Within the Agriculture Department there are college preparatory students, terminal students, as well as some sub-marginal learners needing preparation for gainful employment.

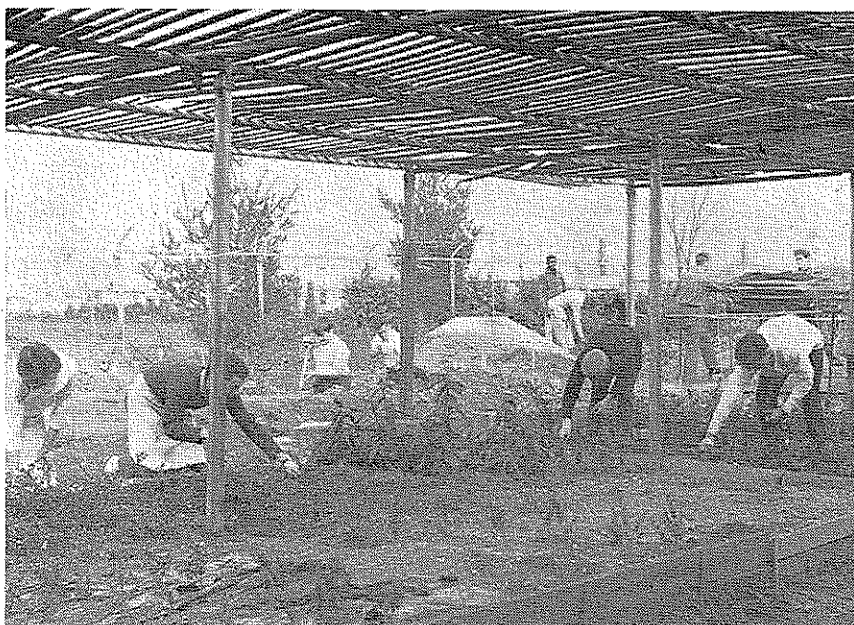

Class working under cold frames and on nursery plot.

We Adjusted our Program to Urbanization

ROBERT A. KOPF, Teacher of Vocational Agriculture, Freehold, New Jersey

The two instructors in this department practice area specialization, facilitated by means of exchanging classes at mid-year. Each teacher is responsible for fifty percent of the curriculum thereby getting to know each student in the department. This understanding of student background by both teachers is of utmost importance for student visitation and supervised agricultural occupation experience. It also facilitates reevaluation of departmental objectives while helping each teacher keep abreast of changing needs in the course of study and methodology.

Three years ago an exploratory course was initiated for the purpose of stimulating interest in vocational careers associated with agriculture. This one-year orientation elective, usually restricted to the freshman year, has been well accepted. About twenty percent of those who take it are challenged to transfer to the regular Vo-Ag program.

Starting in September, 1964, the department will offer the following courses: Freshmen—(1) Exploratory Agriculture—elective for 2½ credits, (2) Technical Agriculture—for Agricultural majors—5 credits. Sophomores—Agricultural Science, Juniors—Choice of: (1) Agricultural Production and Farm Mechanics Technology, (2)

Horticultural Production and Horticultural Mechanics Technology. Seniors—Agricultural Business Management and Advanced Agricultural Mechanics.

There is a Supervised Agricultural Occupation Experience Program required for all agricultural majors. Students may elect either farm or horticultural production projects, or placement for occupational experience in approved agricultural occupations.

Wide Choice Available To Students

All courses are planned on a unit basis. The goal of each is to prepare for employment, regardless of post-high school plans. These courses, in consideration of changing technological and production methods, aim at teaching basic principles and development of attitudes having a high transfer value.

In all high schools in the Freehold Regional System, freshmen may elect exploratory agriculture for 2½ credits or technical agriculture for 5 credits. The latter is for ag. majors and other qualified students. It allows for some homogeneous grouping programmed through the Guidance Department.

Students who wish to continue in agriculture for the sophomore, junior, and senior years must attend the Central School and are provided trans-

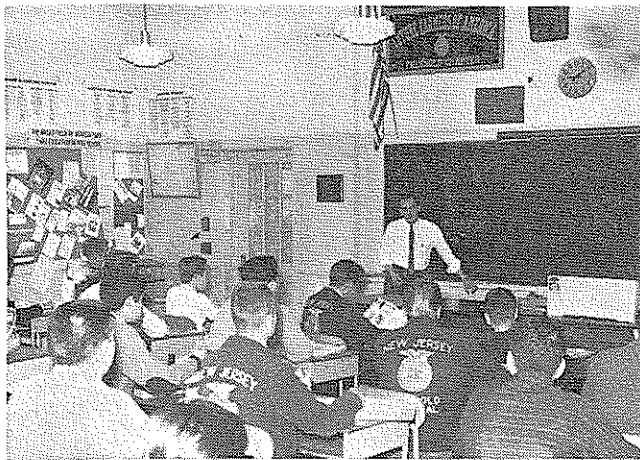

W. A. Smith (other teacher) teaching juniors in the classroom at Freehold.

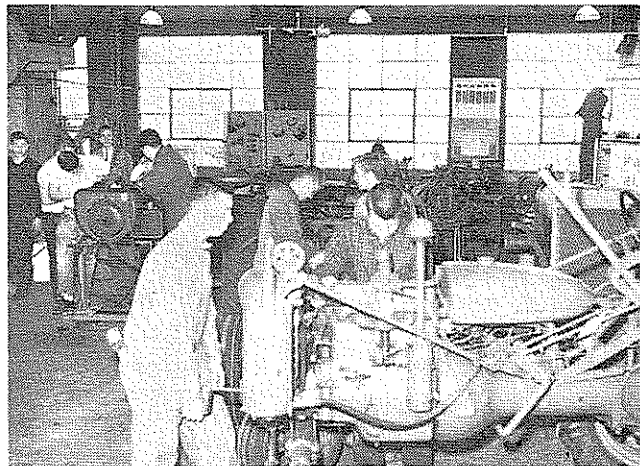

A class in Farm Mechanics at Freehold.

portation thereto as full time students. In these years double period classes are sectioned into approximately fifty percent classroom and fifty percent shop instruction. The school operates on a six-week marking schedule which allows for three-week units taught alternately in the classroom and in the shop and/or greenhouse and nursery.

As is the case in most high schools, all the agriculturally oriented shop skills are taught with individual attention given each student according to his aptitudes and interests. The sophomore year in the shop is devoted to the learning of basic shop skills with the more advanced skills coming during the following years. Qualifying upper classmen are encouraged to work on approved projects brought from home or provided by the department. The shop facilities contain equipment to teach arc and oxy-acetylene welding, metal work, tractor and equipment operation, maintenance and repair, carpentry, electrification, and concrete work. One heated greenhouse with head house, a cold house, two lath houses, and a small nursery for ornamental shrubs facilitate instruction in their respective fields.

Future Developments

Currently the departmental instruction is balanced between farm production and ornamental horticulture instruction. As the community becomes more urban, specialization in ornamental horticulture will receive greater emphasis. At present students may choose distinctive courses only during their junior year as farming and horticulture units are combined within the offerings the other years. Tentative plans are in process to permit this choice of major in the sophomore year also. The agricultural

science offering will be rearranged into Field Crops and Animal Science and Horticultural Science, to provide the concentrated background material required for the junior year specialization.

By special arrangement with the Guidance Department a few special students in a given year are allowed to participate in the shop skills instruction with no academic credit involved. To meet the needs of these students, who require more than one year of instruction, plans are under way to initiate courses in an Occupations Training Program which will concentrate on manipulative skills for pre-employment training in the fields of agriculture and horticulture production and service.

The Agriculture Department realizes it has a big job to do; to make available course offerings applicable for college preparation and terminal training to the heterogeneous grouping of students it serves. It strives to meet the most needs of the majority of students by diversification and specialization and through short and long-term planning for this specific community. □

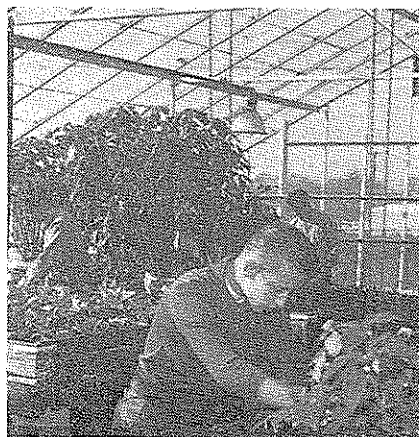

Student working in school greenhouse at Freehold.

From Former Issues

Writing in the February 1934 issue Carsie Hammonds says, "Ray Fife, Ohio state supervisor of agricultural education, was re-elected president of the American Vocational Association during the recent session in Detroit. Dr. Fife's re-election broke a precedent of four years in which no president succeeded himself. His selection for second term was prompted by his energetic leadership of vocational forces in our financial emergency. The re-election comes as an honor to agricultural education.

"A. K. Getman, state supervisor of New York, Professional Editor of this magazine for several years, was re-elected vice-president of the A. V. A., representing agriculture.

"The association voted in favor of establishing a permanent, paid secretary in Washington. L. H. Dennis was elected to this position. Mr. Dennis was formerly state director of vocational education for Pennsylvania and has been aggressive in aiding legislation supporting vocational education. Recently he has been state director in Michigan. Every teacher of vocational agriculture should cooperate in the support of a full-time secretary, whose duty it will be to see that the funds now available are not cut off, thus reducing the program of vocational education in the nation."

Letters . . .

(Continued from page 63)

agriculture must provide a more thorough education for those students who will be farming. The demand of our complex age will be even greater as more scientific and progressive farming is the trend for tomorrow. We cannot afford to overlook the need for those for which vocational agriculture was originally designed.

CLAXTON R. COOK
Teacher Education
Oklahoma State University



John C. Walter

If You Add Horticulture —

JOHN C. WALTER, Vocational Horticulture Teacher, Wheaton High School, Maryland

Have you recently surveyed your school patronage area? Have you found suburbia creeping in? Are there more new homes in your area than there were 5 years ago? Have any industries of any size become established there recently? Are nurseries or garden centers on the increase? Has your community developed any recreational areas or parks over the past few years? If you must answer yes to many of these questions, then perhaps you are not truly meeting the needs of your community. In view of the above findings, perhaps you should consider the possibility of adding horticulture to your existing vocational agriculture program.

The following, then, is an attempt to answer some anticipated questions which might arise if you are seriously considering such a program.

What type of program do I want?

There are two possibilities which exist. If the community is becoming quite suburbanized, the extreme selection would be the development of a strictly vocational horticulture program patterned after Vo-Ag. This is the type which prepares boys and girls for entrance into the fields of horticulture and its ramifications. A program of this type already exists at Wheaton High School, and further information along these lines may be obtained from the teacher there.

The other possibility is adding or expanding horticulture units in the Vo-Ag curriculum. This appears to be the more logical choice for most departments. In a situation such as this, careful consideration should be given as to what aspect of horticulture should be taught. To be more specific, floriculture, ornamental horticulture, olericulture, etc. The emphasis to be placed on this phase of the Vo-Ag program will naturally depend upon the existing conditions in the community and surrounding areas.

What type of academic training should the Vo-Ag teacher possess in order to teach horticulture?

The average teacher of vocational

agriculture usually has had sufficient background in those areas which are common to all phases of agriculture. As pertains to the more specific areas of instruction in horticulture, he may obtain proficiency in these by taking advantage of the following possibilities:

- Summer courses offered by the College of Agriculture
- Winter programs offered by the Horticulture Department of the Universities or Colleges
- Short courses offered by the State Nurserymen's Association
- Keeping in contact with local nurserymen and florists
- Self enlightenment through the study of USDA and University Extension Service Bulletins

Is there a definite relationship between horticulture and Vo-Ag?

The existence of a relationship between these two areas of agriculture can best be shown by the following two statements:

The purpose of a horticulture program is to provide education and training for students interested in a future in the horticulture industry through classroom instruction and on the job training.

This program can be supported by funds under the Federal Vocational Act. It can also be administered by the State Supervisor of Agricultural Education, or Local School District.

The two programs differ in three ways which include, course content, occupational experience rather than supervised projects and sex of students. Horticulture enrolls both boys and girls in almost equal numbers.

What facilities are needed in addition to the existing ones?

It has been generally agreed upon by those who are engaged in the teaching of horticulture that the following facilities are minimum requirements for conducting a program in ornamental horticulture:

- One acre of land for laboratory use.
- Classroom
- Lath house
- Greenhouse
- Compost bins
- Concrete walks
- Water lines for garden plots

These are not necessarily in their order of importance. In addition to these physical facilities certain equipment is also an absolute necessity. This equipment includes a soil shredder, a Roto tiller, several dusters and sprayers, rakes, shovels, hoes, hoses, hand trowels, and pruning shears, and saws.

What possible problem areas might one anticipate in initiating a program in ornamental horticulture?

Problems can come from almost anywhere at any time without warning. However, those engaged actively in the teaching of horticulture suggest the areas below as most common.

1. *Administration.* In some counties problems often arise regarding the operation and financing of such a program. Once the administration understands what the situation is, they are usually very cooperative. Better communication seems to be the answer to this situation.
2. *Selection of qualified students.* This seems to be the bane of all vocational subjects. The students should have sufficient native ability to acquire those skills which prepare them for entrance and pursuit of their occupation.

3. *Selection of Cooperators.* Most high schools do not possess the necessary facilities to train students in all facets of horticulture trades. In view of this, it is necessary for such training to be obtained on the job through practical experience. Finding local men who are interested enough in the future of their industry to cooperate in this "on the job training" often poses a problem.

(Continued on page 78)

Training Future Teachers in Forestry

LUTHER R. HILTERBRAND, Teacher Education, Wisconsin State College, River Falls



L. R. Hilterbrand

Forestry education in the local vocational agriculture departments has increased in the last decade, but has not reached a proportionate number of schools in the midwest commensurate with the need for such instruction. In areas where trees or timber production dominate or influence the economic picture and farm forests occur in picturesque patterns across the landscape many present teachers are attempting to incorporate some forestry instruction into their curriculum. This sporadic instruction occurs when trees are ordered for planting. For planting, in some school forests, and/or school plots or as a retroversion in the curriculum to create outside activity at the end of the school year. Present teachers have not had sufficient course instruction in their undergraduate programs to implement forestry instruction on the local level. To this end and with this view in mind Wisconsin State College at River Falls has attempted to set in motion some machinery which would provide future teachers with experience and knowledge in timber production and management.

Two specific courses in Forestry are being embraced within the agricultural education curriculum at River Falls for future teachers. Farm forest management will emphasize the place of the forest on the farm; tree planting; weeding and cleaning; thinning timber crops; pruning and harvesting; marketing and utilization; management of Christmas tree production; maple syrup production; and fire, insect and disease protection will be presented as a beginning course in forestry. A second course provided for future teachers will acquaint the student with specific aspects of forest management, namely silviculture. This course will continue the instruction by emphasizing both intensive and extensive management of forests with specific areas concerning principles, as well as applications of intermediate and reproductive methods of regeneration. Planting will be considered as a place of forest regeneration. Site factors and its influence upon repro-

duction, growth, development, and the effect upon vegetation will be considered.

Supervised Forestry Experience Provided

Successful forestry instruction must be implemented by field or laboratory experience. For this purpose five acres of the Laboratory farm are used. Successive plantings have been made by interested school groups from 1953-61, until about 4400 Norway and White Pine have survived a 68 percent livability. The trees are planted in a general north-south direction on Boon Sandy Loam. Some undesirable trees are growing on the area that include red cedar, spotted oak, plum and cherry.

The management plan for the school forest will provide each future teacher with the skills necessary to implement forest instruction in a local situation. The plan will be followed in laboratory instruction with each student sharing in the experience of forestry production and management. Basically a tentative forest plan is presented. Plans for various forests will vary due to size and growth as well as use of merchantable products and locale.

Forestry Management Plan Adopted

The initial plan was to establish the area in trees for the purpose of producing sawtimber. It appears this plan is feasible due to the growth being made each year and the good survival made. Other obvious benefits and uses of the forest include the esthetic value, soil coverage, conservation of soil from wind and water erosion and recreation.

First. Thinning operations should include products for pulpwood, Christmas trees, posts and poles. Gradual release of selected crop trees for sawtimber volume is the ultimate goal. Thinning out the major species for the weak, defective and undesirable trees for pulpwood and posts should have prime consideration. After that time the emphasis should be upon pruning, disease and insect control and stand maintenance. A basal area of 70-80

feet would be sufficient for the production of sawtimber volume from the selected crop trees.

Second. A cleaning operation is in order to remove some oak, cedar and other undesirable species and other forms of vegetation. Generally the cleaning should precede any thinning operations that are initiated.

Third. Pruning the crop trees increases the value of the selected crop trees. In this circumstance it would be desirable to prune the selected crop trees to a height of seven feet between the first and second thinning operation and to seventeen feet before the final thinning is made.

Fourth. Replanting crop trees that die from natural causes is necessary. Two trees planted where one crop tree is removed will insure continuous soil cover as well as provide a growing crop all the time.

Fifth. Periodic observations are needed to ascertain and protect the trees from insect and disease damages. Possible spraying of infected trees and/or removal of others by mechanical means may be necessary to provide a continuous protection from diseases and insects.

Looking Ahead

It appears inevitable that forestry will become scientifically more complex as the use of forest products increase. Conjunctively farm forest will eventually be regarded as a crop of agriculture with economic importance which will require training by future teachers in order to implement it into programs of vocational agriculture. Also, training in other areas of plant science such as horticulture, turf management, and ornamental production, will become increasingly important as vocational agriculture trends to broaden its spectrum to include occupations closely allied to traditional programs. Preservice training in a broad area curriculum with emphasis upon areas encompassing many occupations, such as forestry, may well become an enterprising constituent of vocational agriculture on the local level in the near future. □



S. S. Sutherland

More Inductive Teaching Needed

S. S. SUTHERLAND, Teacher Education, University of California, Davis

There has been a recent revival of interest in the inductive approach to teaching. Much of this has come about as a result of the work done to improve the teaching of biology through the efforts of the National Science Foundation and the American Institute of Biological Science. This method also has implications for the teaching of agriculture. It is an application of one of the oldest precepts in teaching in that it "proceeds from the concrete to the abstract." It presents to students situations in the laboratory, in the field, or in the classroom and asks that they search out and find common elements from which they may generalize and state concepts, principles or laws. It thus is a method which emphasizes discovery.

The primary purpose of this method of teaching is to help students find, understand and state principles which have broad applications to agriculture and to agricultural practices. Its use also helps students understand why certain farming practices are followed and why other practices are less desirable. It substitutes giving students a more complete understanding of a large, important truth for an attempt to give students a transitory knowledge of many less important facts. Therefore, it may accomplish a most desirable end in that its use could result in teaching less and teaching what is taught much more thoroughly.

The 22 Principles

In a recent study by the author it was found that the subject matter content in biology which has important relationships to the study of agriculture could be concentrated into some twenty-two broad general principles or generalizations.¹ To illustrate the manner and the extent to which one of these principles relate and apply to farming practices, let us consider a principle dealing with ecol-

ogy which states, "Each species of living organism has a range for each physical condition of environment outside of which it cannot survive. Inside this range is the optimum where these organisms thrive."

Practically everything which the farmer does in producing high yields and quality products of the crops and livestock which he grows relates back to and is based upon this principle. In producing a given crop, he first selects a variety which is generally well adapted to the climatic and soil conditions under which it is to be grown. He prepares a seedbed which is most conducive to germination and to giving the young plant a favorable start. He adjusts the rate of seeding to reduce undue competition. When he fertilizes, irrigates, thins, cultivates, and sprays to eliminate or reduce insect pests, he is adjusting and augmenting the environmental conditions to come as close as possible to the optimum for that crop. Nor does he confine his efforts to adjusting the environment to the crop. When he prunes trees and vines, dehornes cattle, selects replacement stock for his breeding herd, castrates pigs, and docks lambs he is adjusting these organisms to better fit their environment and to thrive. The "greenhouse farmer" who produces hothouse fruit and vegetables in the off season and the grower who produces broilers for the poultry market are examples of where man goes to the extreme in adjusting the environment to the plant or animal he grows. These are just a few applications of this biological principle to farming practices.

The agriculture student who understands this principle has a frame of reference which should make the specific facts which he is taught, dealing with the production of crops and livestock, much more understandable and meaningful. Furthermore, an understanding of this principle and how it applies to farming practices may well reduce the number of facts which he may need to be taught.

An Example of Inductive Reasoning

To bring students to the place where they might discover and state this basic principle of ecology, the teacher could present the following problem to his class:

"Some of the best deer and elk hunting in the United States today is found in the Bitter Root and Selway Mountains of northern Idaho. However, the early history of this part of the country tells us that before the fertile valleys adjacent to these mountains were settled, deer and elk were plentiful in the valleys and that soldiers crossing these mountains on horseback and on foot during this period were in danger of starvation due to the lack of game in the high mountains.

"Plants in areas of high rainfall have many large leaves; those in desert areas have only very small leaves or thorns.

"On the Shetland Islands, feed is reported to be very scarce, and it is said that in some years the ponies which live on these islands are able to survive only by eating kelp and seaweed. As you know, the ponies which come from these islands are very small. Nearby are the Jersey Islands, and Jersey cattle are noticeably smaller than the other dairy breeds.

"The Brahma breeds of cattle which are native to India have loose skin and sweat glands; other breeds of beef cattle such as the Hereford, Angus, and Shorthorn were developed in the British Isles and are without these characteristics.

"What is the primary reason for these situations?"

The primary reason or cause for each of these situations is of course the ecological principle that "In a changing environment, living organisms can survive only through adaptation and/or migration; each species of living organism has a range for each physical condition, outside of which it cannot survive."

Once the principle is discovered and stated by the students, they are

(Continued on page 70)

¹Sutherland, S. S., and W. E. Sams; "Biological Principles in Agriculture"; California State Department of Education, 1963.

Barriers to Good Relationships

J. C. ATHERTON, Teacher Education, University of Arkansas



J. C. Atherton

Several years ago while on a trip, the writer drove by two rural houses with adjoining yards. In between these yards was a crude fence—a solid wall several feet high of rough slabs of wood. Both yards were neat and well-kept with flowers blooming and the homes appeared attractive. In such a situation it is natural for one to wonder why a fence of this type was standing to mar the beauty of the surroundings. A sign in one of the yards provided the answer. These words appeared on the neat, well-lettered sign: "This fence built by ----- for spite."

No doubt many persons have viewed this scene and reacted to it in a variety of ways. The consensus of the group with the writer was that it's a shame that people could not be good neighbors and that a spirit of cooperation would have been much preferred over one of spite and backbiting. The scene elicited considerable comment and speculation on reasons for the construction of the fence and what might be done to induce the owner to remove it voluntarily.

Watch for Barriers

Possibly a close look at some of our programs in agricultural education would reveal that ugly fences have been erected as barriers between

us and the neighbors. Possibly we have permitted a misunderstanding or a small incident to grow all out of proportion to its importance, and then for years we reap the fruits of a thoughtless moment. In the words of the man protesting a situation to his city council, "Gentlemen, this should not be!"

Some of us are familiar with the words of the American poet that good fences make good neighbors. We would probably agree that this makes sense for livestock farmers, but that for most of us in our work the problem is one of removing fences and other barriers to communication and cooperation. A well-rounded program in agricultural education has cooperation as a cornerstone in its foundation.

A department of vocational agriculture can prove its worth as a good neighbor by careful consideration of its participation in community affairs. Too often the department faces charges of isolationism and indifference or lack of interest in the activities of the community that are not directly related to the work of the teacher of agriculture. Much of the prejudice emanating from such charges can be dispelled by putting practical public relations judgment to work.

The department of vocational agriculture has a mission in relation to

the public school and local persons engaged in agricultural pursuits. It has a mission also with regard to the community as a whole. Being a vital, respected, influential force in the community should be a major concern of the teacher of agriculture. He must accept the fact that he, as teacher, is the key to the successful operation of the department.

It is recognized that the effective teacher of agriculture is a busy man. He should be, as there is much to be done in the community. The big problem is one of improving his efficiency and of multiplying his effectiveness. A good program of public relations will help him reach this objective.

Three Suggestions

First of all, the teacher must see a need for good relationships. He must visualize it as an aid to accomplishing the objectives and goals of the community program of vocational agriculture. It is the means for securing wholehearted cooperation of the school faculty and of other local workers in agriculture in the community. It is the device for opening doors, removing barriers and for securing assistance in the promotion of worthwhile activities.

(Continued on page 71)

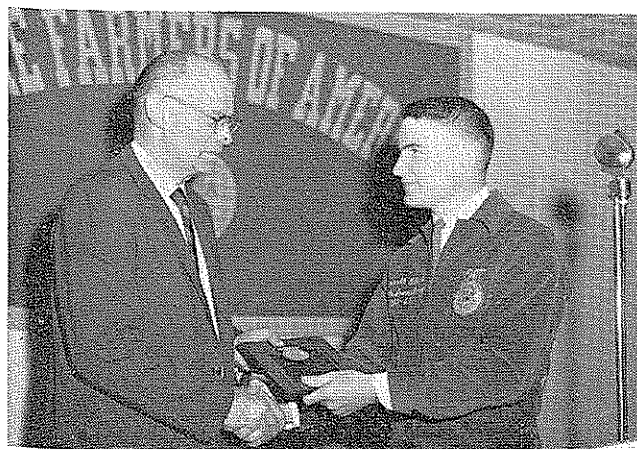

Appreciation may be expressed through the presentation of a plaque or other similar device.



Teaching skills on the farm involves the parent as well as the high school student.



Anthony Juestrich

A New Jersey Department Emphasizes

Horticulture and Forestry

ANTHONY JUESTRICH, Teacher of Vocational Agriculture, Mays Landing, New Jersey



Students taking increment bores to determine age of tree and rate of growth.



Students determining timber yield.

Oakcrest Regional High School, Mays Landing, New Jersey, serves 360 square miles of which a great part of the area is rural. For the past four years vocational agriculture instruction has been focused on the farming enterprises of the area: poultry, livestock, fruit and vegetable production. Even though the community resources have been heavily tapped for the instruction in these phases, it has been recognized that a better job of vocational training in agriculture could be accomplished if specialization could be achieved in two new areas of agriculture: conservation and ornamental horticulture.

A Curriculum for Nonfarm Students

The course of study for the agriculture department originally had been geared to the agriculture of the community. In the opinion of the author, a new emphasis for Vo-Ag is needed since the students no longer represent the agriculture of the community. Students are not products of the farm; they have little opportunity to get into farming since farm units are large, heavily mechanized and extremely competitive; land values are high and taxes are burdensome.

A constructive program in conservation is now underway. Utilizing 80 acres of school woodland, students are receiving instruction in such forestry topics as: managing farm woodlots; using harvesting tools; culling the farm woodlot; determining timber stands; identifying woods; identifying forest insects and diseases; using chemicals in the woodlot; marketing; learning the duties of fire tower observatory work; using control and prescribed burning in the woodlot. Practicing these phases of instruction during the past year, the agriculture department has successfully managed 20 acres of woodland, marketing the cull timber as fireplace wood. A large demonstration woodland management plot has been developed on school grounds.

Students are receiving instruction in soil conservation topics, such as:

using a transit; using a farm level; determining elevations; planting forest tree seedlings on the contour. By putting these phases of instruction into practice, the department has laid out and determined all elevations and necessary data for the construction of school athletic fields; planted trees on contour; seeded banks against erosion washouts. The services of many specialists, such as district forester, forest warden, farm forestry extension specialists, forest entomologists, and soil conservationists have been secured to assist with the instruction.

Greenhouse Production Taught

Nursery and greenhouse crop production is increasing in our area. Our department initiated work in this area by constructing a small 12' x 24' plastic greenhouse. Students secured second-hand lumber which was used for the framework. The heating and

ventilating units and controls were donated by the local electric company, but the cost of installation was paid by the school board. During the past four years, in coordination with classroom instruction, vegetable seedlings have been started and spotted into four inch bands; nursery stock has been propagated. Chrysanthemums have been produced and marketed as corsages for football games. Every item produced has been marketed with the profits deposited into our F.F.A. treasury.

The important result of our program changes has been the increase in student enrollment and the desire for students to continue in their agricultural endeavors. An Advisory Council has been formed and is paving the way for the development of commercial type facilities for the training of personnel in nursery and floral crop production. □

There's a Place for *Teaching Landscape Design*

EDWARD C. DIPPOLD, Teacher of Vocational Agriculture, Allentown, New Jersey



Edward Dippold

What is the importance of landscape design? Today, New Jersey and other states are faced with the growth of industrial and residential areas. Although our areas of natural beauty are being transformed into more useful purposes with this expansion, we should never lose sight of planning growth not only with a practical purpose but also with an aesthetic one. For instance, take a look at the industrial buildings erected a few years ago, and compare these buildings with the buildings of today. Today's industrial surroundings express an invitation to work. Landscape design is partially responsible for modern industry's aesthetic appeal.

Not everyone can become a professional landscape designer but a well-taught unit of landscape design has a place in the Vo-Ag curriculum. People who understand and appreciate the principles and nature of a good landscape want their home surroundings to be pleasant and func-

tional. The selection of landscape design as a teaching unit cannot only train students for a profession, but also can satisfy their own demands as future homeowners.

Main Objectives

1. The unit of landscape design gives the student an insight into the aesthetic value of design. Through understanding the logic of nature and the importance of landscaping, the student can analyze, appreciate, and know the necessity of artistry in the landscape.
2. A knowledge of landscape principles is essential in order to achieve this creative beauty in a design.
3. Students develop skills in using both mechanical and freehand drawing to meet the requisite of formal presentation of their ideas.
4. The student learns to identify, select, and use appropriate ornamental plants correctly. In his selection, he must know what trees and shrubs will be suitable for foundation, border, and other plantings.
5. A landscape must be maintained or its value will eventually be lost. Therefore, the student develops skills

in maintaining lawns, plants, and trees.

To sum it up the end result of a unit of instruction in landscaping is to develop the student's appreciation of the landscape designer's needs and job opportunities.

The following is a brief outline covered over a four year period with thirty class hours of instruction devoted to each year.

Agriculture I Initiatory Phase

- I. Aesthetic value
 - A. Understanding the unity and logic of nature
 - B. Analyzing the reasons for landscape design
- II. Principles of landscaping
 - A. Understanding the principles of plant placement
 - B. Analyzing areas of the home grounds
 - C. Incorporating maintenance in the landscape
 - D. Understanding basic plant types
- III. Designing a public area
 - A. Developing skills in drawing aerial view plans
 - B. Drawing a public area plan for a simple building

Agriculture II Developmental Phase

- IV. Plant characteristics
 - A. Harmonizing with color
 - B. Using fragrance in the landscape
 - C. Determining the time of flowering
 - D. Analyzing characteristics in relation to landscape principles
- V. Studying ornamental trees and shrubs
- VI. Landscaping a home or public building
 - A. Measuring a property
 - B. Planning the public area
 - C. Carrying out a landscape plan

Agriculture III Developmental Phase

- VII. Maintaining the appearance of the landscape
 - A. Establishing and maintaining lawns
 - B. Pruning ornamental plants
 - C. Understanding special soil conditions
 - D. Controlling insects and diseases
- VIII. Landscape feature (a structural focal point)
 - A. Understanding the purposes of a feature
 - B. Designing a feature
 - C. Incorporating a landscape feature into a flower garden plan
- IX. Incorporating the private and service areas into a landscape plan

Agriculture IV Culminating Phase

- X. Analyzing other areas of use for landscaping (Religious, public, and commercial buildings; parks and recreation areas)
- XI. Analyzing job opportunities in landscaping
- XII. Term project—a dream landscape business for a year

(Continued on page 71)

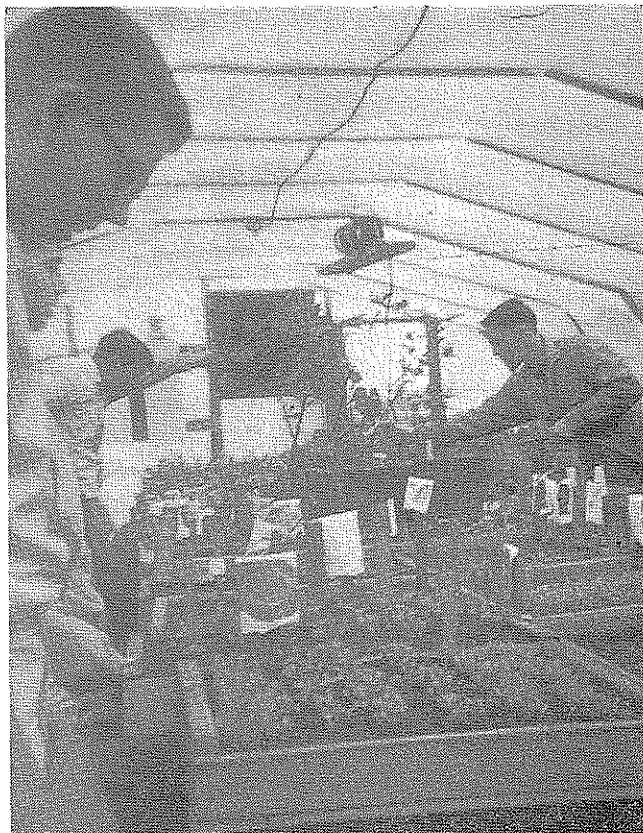

A Greenhouse in Your School

JOEL PYNCH, Vocational Agriculture Teacher, St. Paul, Oregon

Hardwood cuttings, Elwood Cypress, propagation bench, and hormone rooting powders are just a few of the new vocabulary terms of students enrolled in Vocational Agriculture at St. Paul High School in the small rural school in St. Paul, Oregon. To meet the expanded Vocational Agriculture program of the state, the St. Paul Vocational Agricultural Department has incorporated instruction in greenhouse and nursery work in their program.

The purpose of the program is threefold: To develop skills in preparing plant materials for propagation, potting, field planting, grafting, maintenance and experimentation; To establish interested students in the vocations of Floriculture and Horticulture; To nurture the desire of students to understand and appreciate the growth and reproduction of the plant kingdom.

New Greenhouse Built

To meet the requirements of the new vocational program, a 960

square foot greenhouse was constructed in September of 1963 by the Vocational Agriculture students as part of their classroom instruction. The structure is of redwood construction and covered with a 4 mil. polyethylene outside skin and inner liner. The floor has a black plastic moisture barrier covered with 4" pea rock and sand. Cuttings are propagated on an 18-foot heated bench equipped with a time-clock controlled mist system. Heat for the house is provided by a used butane floor furnace that is controlled by a thermostat. Cost of the greenhouse and supplies to begin operation was \$500.

The greenhouse instruction began in November when students gathered and prepared hardwood cuttings for their individual propagation boxes. Each student has an additional six square foot area where other plants are propagated by seed and cuttings. Experiments involving heat, light, moisture, oxygen, rooting hormones and propagating medias are being carried out by the students to help

explain and make the science of botany more meaningful. Other recent activities include grafting malling root stalk, budding roses, aerial and ground layering, orchard pruning, and tree planting.

Adult Classes Use Greenhouse

What do the students think of this new vocational agriculture program? The excitement generated by a single twig sending out a new root to regain life will bring a smile of delight to all the students in the program. Students work in the greenhouse during lunch hour and even drop by after school to ask if there is something that they can do in the greenhouse.

At the present time, the classes in greenhouse and nursery work are confined to the 10, 11, and 12th grade level boys enrolled in Vocational Agriculture. The classes are carried on according to the time of the year the skill is practiced in the commercial greenhouse. A recent 3-week exchange session with a class in Home Economics allowed even the girls to use the facilities.

A class of twelve adults completed their first thirty hour term in plant propagation. Each adult was able to propagate several types of plants in the greenhouse. There are plans for at least one more term beginning in August which will deal with propagation of soft wood cuttings.

The future plans of the program include developing a foundation stock nursery for ornamental cuttings and horticultural root stock materials, experiments in field-grown vegetable crops and the development of a Vocational Agricultural on-the-job training program involving commercial nurseries in the area. □

Inductive Teaching . . .

(Continued from page 66)

well on the way to understanding it. Further and more complete understanding may be developed by assigning problems for students to study and solve which require them to apply the principle which they have developed.

Teaching inductively, then, is simply guiding and directing the learning activities of students so that they are brought face to face with situations, actual or contrived—in the field, the laboratory, or the classroom—which involve, illustrate, and are the effect of the principle to be discovered and identified. As a result of conducting experiments, observing demonstrations, listening to described situ-

ations, making field observations, students are expected to search for elements and causes which are common to all these situations, to find the common elements, and to bring them together into a general statement or generalization. This is to be done, of course, with the assistance of the teacher, but any statement of the principle involved is not to be made by the teacher nor stated by him until discovered and stated by the students.

When Is a Principle a Principle?

It is quite obvious that many who talk and write about principles have a vague and limited knowledge of what a principle really is. A careful reading of many high school and college texts entitled "Principles of _____" fail to reveal a single statement which bears any resemblance to a principle. These publications contain many facts of greater and lesser importance, and some rules, but the title in most cases belies the content. Furthermore, principles may be confused with "laws," "rules," and "concepts." This happens because all of these are truths and all are generalizations. Let us examine the characteristics of each of these.

A principle is a generalization which is based upon facts and upon elements of likeness common to a number of situations. It is a fundamental truth; a law of conduct which has general application and is a basis for action.

A law may be defined as a principle which is invariable under given conditions. A principle may be generally applicable, but not invariably. In other words, there may be exceptions to a principle; not to a law.

A concept is a generalization made by an individual. It is a mental image based upon an understanding of all that is associated with or suggested by a term. Someone has said that a principle is a concept which is generally accepted by many persons.

A rule is based upon or grows out of a principle or law and is a specific direction or procedure for action. For example, based upon the principle of diffusion and osmosis could be developed the rule "Always water a lawn thoroughly after an application of commercial fertilizer such as ammonium sulphate."

Five Reasons for Inductive Teaching

Teaching inductively has much to recommend it. True, it takes more time to cover a given subject; more

teacher preparation is involved to set up the necessary problems, demonstrations, field trips, etc., but there are compensations which offset these disadvantages.

1. Discovery is an inherently interesting process and the inductive approach is the discovery approach.

2. Teachers using it may tend to cover fewer subjects and to teach them more thoroughly.

3. Centering teaching around broad principles which have wide application should result in students emerging with greater understanding of the practices which are based upon these generalizations.

4. Since the inductive process is a thinking process, students are taught to think; given practice in thinking, especially if deduction is added to induction, and if students are required to apply what they have discovered.

5. Science teachers are being taught to use this improved teaching procedure. We can hardly afford to drop behind the parade. □

Landscape Design . . .

(Continued from page 69)

The Core of a Landscape Unit

Everyone has fond memories when they have let their imagination wander. The landscape designer also uses his imagination and plays the textures, colors, and many other assets of construction and plant materials, one against the other. His imagination, however, is not simply a vision but is a concept which creates a complex and intellectual appeal in his work which others can enjoy.

The procedures of the designer as stated reflect the "flavor" of landscape designing. The basic procedures in teaching landscaping therefore are to develop the imagination of students to logically combine plant characteristics and construction materials into a unit which has as its core simplicity and aesthetic appeal; and secondly, to provide the students with the opportunity to actually participate in the design and execution of a worthwhile landscaping project. □

Good Relationships . . .

(Continued from page 67)

Second, the teacher must take the initiative in establishing and maintaining satisfactory relationships. Good relations don't just come into being automatically. Someone has to instigate them.

Third, the teacher must be responsible for keeping relationships operat-

ing smoothly. A yard will soon become ragged if neglected, a bearing will burn out shortly if it does not receive oil. Likewise, weeds of indifference and the friction of day by day contacts will tend to play havoc with the community program of agricultural education whenever public relations are neglected.

School Relations

It is essential to have a thorough understanding with the school administration and the board of education as to the duties and the relationships of the teacher of agriculture. Without this knowledge, the teacher is operating on a basis of guessing and hope. Many misunderstandings result from the lack of an initial understanding. It should be recognized, however, that it is impossible in the initial understanding to cover every possible situation that may occur within the next several years. Also in emergency situations everyone is expected to give assistance regardless of the special field with which this activity is usually associated. Someone has said that when the boat is sinking everyone is expected to bail water.

In any school system, there are certain extraneous duties which by their very nature are not the responsibility of any particular member of the teaching staff. The wise teacher accepts willingly his full share of these activities.

The teacher should recognize and follow the lines of authority and communication within the school system. There should also be a high degree of loyalty to the administration, the co-workers and the school system in general. This does not imply that the teacher will blindly accept every situation that arises in the operation of the school as being perfect. However, it does mean that the teacher will not wash in public the "dirty linen" of the school.

A friendly greeting and a little personal concern for the problems of the non-certificated school personnel will pay dividends. Maintenance personnel, lunchroom workers, and bus drivers all have various contacts within the school and the community. They have numerous opportunities to make a favorable comment (or a derogatory one) about the teacher and the educational program.

Relationships with the students are important too. Each of them will eval-

(Continued on page 77)

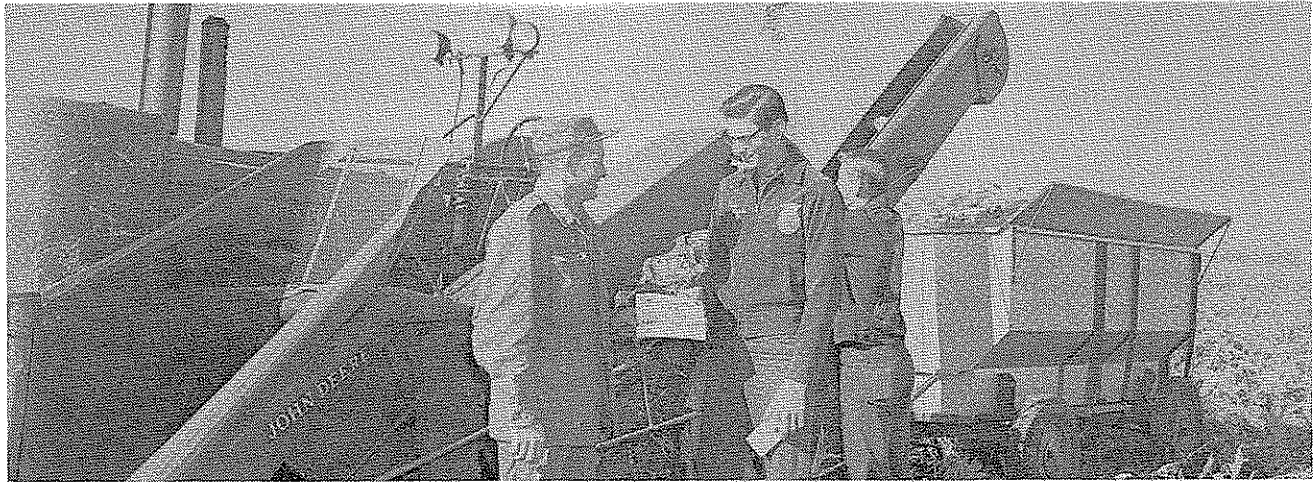

Sam Sickles, a Mount Ayr farmer, receives the full safety treatment from FFA members Lyle Fairs and Carl Schafer.

Iowa Vo-Ag Department Campaigns for Safe Corn Harvest

R. E. HAUPTMANN, Vocational Agriculture Teacher, Mount Ayr, Iowa



R. E. Hauptmann

Program kits for the 1963 Safe Corn Harvest Program were issued to instructors at the State Vocational Agriculture Teachers Conference held early in July. I immediately examined the kit of materials, familiarizing myself with the contents and procedures.

FFA officers and members were contacted regarding the program. I visited with members as I contacted them on their home farms during the months of July and August. Chapter members discussed the 1963 Safe Corn Harvest Program at the regular chapter meeting held July 16. When school opened the new year in August, we discussed the program in each of the five day school classes. At the regular chapter meeting held Sept. 17 members discussed the 1963 Safe Corn Harvest Program and voted to set our goal at fifteen farmers contacted per member. Procedures for conducting the program were discussed and the ground work laid for the program on the local basis. Using the order blank enclosed in the kit, additional materials were immediately ordered from the office of the State Supervisor of Agriculture Education.

Student Officers Named

Class officers were elected in each of the five day school classes, and these officers were designated as the class Safety Committee. Three members of the FFA Safety Committee contacted all implement dealers, the bank, and a farm management service in town. They explained the purpose of the Corn Harvest Safety Program and how the FFA proposed to conduct the program. As a result of these contacts seven firms subscribed to contributions to pay for a one-fourth page advertisement in our local newspaper for two issues.

The safety chairman of each class prepared a chart of his class members; Safety committee members of each class prepared 6" x 9" envelopes containing safety materials needed by each class member in contacting farmers. Each class member was provided with these materials in his respective envelope.

Class time was devoted in each of the five classes acquainting members with techniques to be used in making interviews with farm families. The value of a life was discussed and how much a man's life contribution is worth to his family and his community. Members were urged to tie one arm to their body for one day, in order to grasp the real value of the usefulness of that arm, in everyday life. A good farm safety film was

shown in each class. Some students related experiences which had been related to them by neighbors who had been victims of farm accidents in years gone by. The tragedy of farm accidents was emphasized.

Each class safety chairman discussed with his respective class members the farming area to be covered by each member. A 4' x 8' bulletin board bearing a plat of each of the 17 townships in the county, and an alphabetical list of farmers living in each township was used. Every effort was made to make sure all farmers were contacted.

Making Farm Contacts

Each week of the corn harvest season the safety chairman of each class checked his membership progress. Problems encountered by chapter members were discussed in class. Ideas and experiences were exchanged by members. This exchange of experiences served as a stimulus to all members to do a better job.

As the corn harvest season progressed and class safety chairmen checked the progress report weekly, competition developed between classes. As progress and accomplishment were reported by classes each week, members became aware of the "slow doers." Without my knowledge class members were assuming the responsibility of talking with and encouraging these boys.

Farmers Appreciate The Campaign

The Mount Ayr Chapter FFA has participated in the Safe Corn Harvest Program each year since its beginning in 1957. The chapter has framed Gold Award Winner certificates for each of the years that they participated.

Why does the Mount Ayr Chapter continue their safety program year after year? Community acceptance is a real stimulus. One farmer said, "I want one of these safety stickers on my machine as a constant reminder." A farm wife expressed her interest in the program thus, "I appreciate the reminder card on the dining room table. This is one place where the entire family meets three times a day. This card is a constant reminder of work clothing which needs repair. Too, I am reminded to have a snack ready at mid-morning and mid-afternoon." □

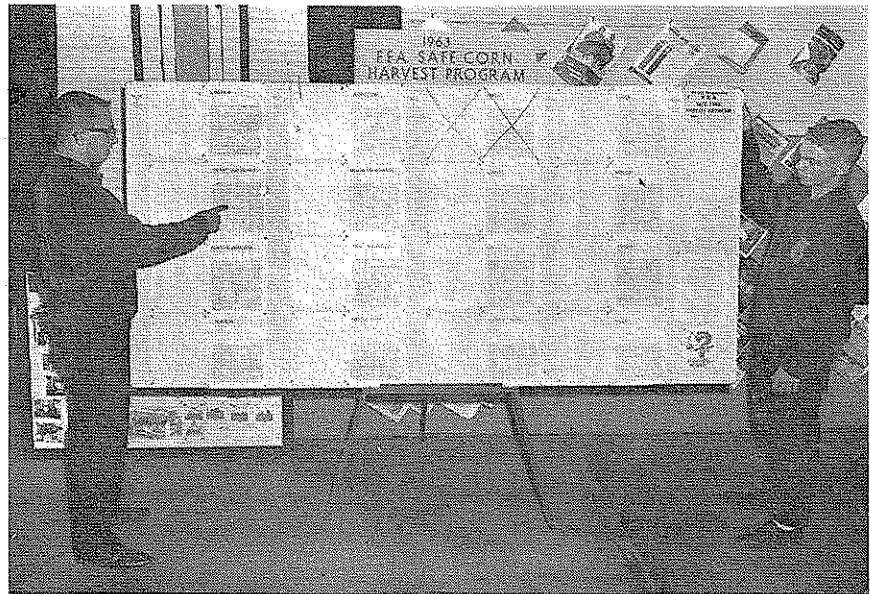

Two FFA members checking the bulletin board to determine farmers and their farm location, in selecting those farms to contact regarding the Corn Harvest Program.

Studies in Progress in Agricultural Education

GLENN Z. STEVENS, Teacher Education, The Pennsylvania State University*



Glenn Z. Stevens

The annual list of studies in progress has been printed in recent years in issues from June to October. Regular readers use the lists for several important purposes. Supervisors, teacher educators, and teachers read the titles for indication of trends in emphasis in research. Current areas of increasing significance may be identified by their appearance in similar wording in studies underway in several states.

This year almost half of the new titles represent efforts to survey career opportunities and educational needs in positions other than farming and ranching that involve knowledge in agriculture. There are curriculum projects of state departments of education which reflect the influence of the Vocational Education Act of 1963.

Pilot programs of preparatory education for employment in many jobs in addition to farming likely will be established on the basis of plans that have experimental or developmental

research built into the design. These titles will appear in larger numbers next year. So, too, will studies of curriculum advances that have students take subjects in two or more vocational fields. Research on cooperative education experience will draw upon our long-time experience with supervised farming programs as its worth in meeting diversified needs in smaller schools is proven.

The report of the Second Research Coordination Conference on Agricultural Occupations at The Ohio State University in January, 1964, is a source of current information on the design and present status of occupations studies in many states. It is likely that research projects and pilot programs financed with funds of the Vocational Education Act of 1963 will call for publication of separate lists of the titles, institutions, and leaders.

Attention of staff members and graduate students using the list of "Studies in Progress" for bibliographical purposes is called to the policy that new study titles are listed only once. The editor will publish in the October issue a list of all studies

completed in 1961-62 and 1962-63, the two years since the annual Summaries of Studies series was suspended. This will be a valuable new service of Agricultural Education Magazine.

NORTH ATLANTIC REGION

Compiled by Glenn Z. Stevens
Pennsylvania State University

ANTOS, DANIEL J., "Instruction Offered in Forestry Conservation Theory and Practice in Selected Departments of Vocational Agriculture in New York State Public Schools." Essay, M.Ed., Agricultural Education Division, Cornell University.

BAILEY, JOSEPH K., "Non-Farm Agricultural Occupations for Which Training May be Provided by Vocational Education in Agriculture in West Virginia" Staff Study, Bureau of Vocational and Adult Education, West Virginia State Department of Education, Charleston.

BEEBE, CLYDE S., "A Study of Leadership Training Needs of Se-

*Professor Stevens is currently chairman of the research committee of the Agriculture Section of the American Vocational

- lected Leaders in a Rural Community." Essay, M.Ed., Agricultural Education Division, Cornell University.
- BELL, ARTHUR P.**, "Characteristics and Performance of High School Graduates and Non-Graduates Enrolled in Industrial Education Centers in North Carolina." Thesis, D.Ed., Department of Agricultural Education, The Pennsylvania State University.
- CHREIN, GEORGE**, "The Changing Outlook for Career Opportunities in Agriculture." Curriculum Development Project, New York State Education Department, Albany.
- COCKROFT, DONALD E.**, "The Role of the State FFA Executive Secretary." Thesis, M.S., Department of Agricultural and Extension Education, University of Maryland.
- COOK, JAMES L.**, "An Analysis of Resource Programming Using Three Methods of Collecting Information Employed by Farm Management Specialists and Teachers of Agriculture." Thesis, D.Ed., Department of Agricultural Education, The Pennsylvania State University.
- CUSHMAN, HAROLD R., CARTER, JULIAN M., and NOHLE, ERNEST F.**, "Reorganizing the Course of Study in Agriculture for Preparation for Farming." Curriculum Development Project, New York State Education Department, Albany.
- DEMICK, DONALD G.**, "The Agricultural Engineering Technology Curriculum." Essay, M.Ed., Agricultural Education Division, Cornell University.
- DITTENHAFFER, CLARENCE A., JR.**, "Comparison of Programmed and Standard Correspondence Courses on the Home Greenhouse." Thesis, M.Ed., Department of Agricultural Education, The Pennsylvania State University.
- DRAKE, WILLIAM E., CARTER, JULIAN M., and NOAKES, HAROLD L.**, "Developing a Training Program for Occupations in the Field of Conservation." Curriculum Development Project, New York State Education Department, Albany.
- HEANEY, DONALD S.**, "Vocational and Technical Training Needed for Off-Farm Agricultural Occupations in Selected Communities of Montana." Thesis, D.Ed., Department of Agricultural Education, The Pennsylvania State University.
- HULL, WILLIAM L.**, "A Procedure for Ordering Self-Instructional Materials for Concept Attainment of Human Relations Skills and Abilities in Agricultural Business Occupations." Thesis, D.Ed., Department of Agricultural Education, The Pennsylvania State University.
- JUDGE, HOMER V.**, "Employment Opportunities and Needed Competencies in Agricultural Occupations Other Than Farming." Staff Study, Division of Vocational Education, University of Massachusetts.
- KING, J. FRED**, "Management and Educational Applications of Resource Programming for Pennsylvania Swine Production." Thesis, M.S., Department of Agricultural Education, The Pennsylvania State University.
- KORONA, ROBERT L.**, "Education for Horticultural Occupations in the Proposed Blair County Area Technical School." Thesis, M.Ed., Department of Agricultural Education, The Pennsylvania State University.
- LASAP, SOTERO**, "Relationship Between Selected Pre-College Experiences and Success in Teaching Vocational Agriculture." Thesis, M.S., Department of Agricultural and Extension Education, University of Maryland.
- MARTIN, W. HOWARD**, "Area Determinants of Non-Farm Education in Agriculture." Staff Study, School of Education, University of Connecticut.
- MASLEY, PHILIP**, "Curriculum Development for Non-Farm Agricultural Occupations in Connecticut." Dissertation, D.Ed., School of Education, University of Connecticut.
- McMULLEN, JAMES R.**, "Factors in the Development of Modern Programs of Vocational-Technical Education in Agriculture in Suburban Compared with Rural Farm Communities." Thesis, M.S., Department of Agricultural Education, The Pennsylvania State University.
- RENZELMAN, ALFRED W.**, "Principles and a Program for Exploration and Guidance in Agricultural Occupations." Essay, M.S., Agricultural Education Division, Cornell University.
- ROBINSON, WILLIAM A.**, "An Experiment in Methods of Training for Employment in Ornamental Horticulture Occupations." Thesis, D.Ed., Department of Agricultural Education, The Pennsylvania State University.
- SANDERS, J. O.**, "Structuring the FFA to Accommodate New Programs in Agricultural Education." Staff Project, New York State Education Department, Albany.
- SANDERS, J. O. and WOLFF, FRANK J., JR.**, "Developing a Course of Study in Ornamental Horticulture." Curriculum Development Project, New York State Education Department, Albany.
- SHOWERS, SAMUEL A., JR.**, "Management Decisions of Young Adult Farmers Concerned with Clean Egg Production, Cleaning Practices, and Marketing." Thesis, M.Ed., Department of Agricultural Education, The Pennsylvania State University.
- SMITH, ROBERT A.**, "Developing a Course of Study in Farm Mechanics Based Upon Evaluations of the Current Program by Specialists." Thesis, M.Ed., Department of Agricultural Education, The Pennsylvania State University.
- SOMERS, MELVIN**, "A Comparison of Selected Characteristics of FFA and Non-FFA Boys in Vermont." Thesis, M.S., Department of Agricultural and Extension Education, University of Maryland.
- WOLFF, FRANK J., JR. and GRADONI, E. JOHN**, "A Survey to Identify the Job Competencies in Agriculturally Related Business Occupations." Curriculum Development Project, New York State Education Department, Albany.

SOUTHERN REGION

Compiled by G. L. O'Kelley, Jr.
University of Georgia

- ALFREY, GARVIN F.**, "Former Student Evaluations of Vocational Agriculture in Area I of Texas by Level of Education." Thesis, M.S., Department of Agricultural Education, Texas Technological College, Lubbock.
- BROWN, HERMAN D.**, "A Study of Opinions Related to Vocational Agriculture of Selected School Personnel." Thesis, D.Ed., Department of Agricultural Education, Oklahoma State University.
- BROWN, WILLIAM J., JR.**, "A Study of Socio-Economic Values in Relation to Tobacco Yields." Problem, M.Ed., Department of Agricultural Education, North Carolina State College, Raleigh.
- EADDY, VANIK S.**, "Some Suggestions for Welding Instruction in Departments of Vocational Agriculture in Louisiana." Thesis, M.S., Department of Vocational Agri-

- cultural Education, Louisiana State University.
- EDINGTON, EVERETT D.**, "Determining Training and Educational Needs for Persons Employed in Agricultural Occupations in Oklahoma." Staff Study, Department of Agricultural Education, Oklahoma State University.
- EZELL, DANNY O.**, and **SIMPSON, DREWY**, "An Appraisal by Peach Producers in Spartanburg County, South Carolina, as to Educational Needs of Owners and Employees." Staff Study, Department of Agricultural Education, Clemson College, Clemson, South Carolina.
- GRIMES, JESSE F.**, "Use of Improved Practices in Soybean Production." Problem, M.Ed., Department of Agricultural Education, North Carolina State College, Raleigh.
- HARMAN, E. T.**, "A Study of Occupational Opportunities in Rice Farming and Farm Based Business in Acadia Parish." Thesis, M.S., Department of Vocational Agricultural Education, Louisiana State University.
- HILL, RONALD**, "Occupational Follow-up Study of the High School Graduates of Vocational Agriculture in Oklahoma for the Years 1959-1963." Report, M.S., Department of Agricultural Education, Oklahoma State University.
- KUNTZ, ROBERT** and **EDINGTON, EVERETT D.**, "Characteristics of Trainees in Farm Mechanics Retraining Schools in Oklahoma under the ARA and Manpower Acts." Staff Study, Department of Agricultural Education, Oklahoma State University.
- LAW, CHARLES J., JR.**, "Relationship of Position and Tenure to Role Expectations." Thesis, M.Ed., Department of Agricultural Education, North Carolina State College, Raleigh.
- LINKER, JERRY M.**, "A Study of the Skills Needed by Vocational Agriculture Students for Employment in Farm Machinery Businesses." Thesis, M.S., Department of Agricultural Education, East Texas State College, Commerce.
- MANN, MILTON M.**, "Analysis of Agricultural Businesses at Littlefield, Texas, with Emphasis on Educational Needs." Report, M.S., Department of Agricultural Education, Texas Technological College, Lubbock.
- MORRISON, RICHARD G.**, "Development of Techniques and Procedures for Determining Occupational Opportunities for Students of Vocational Education in a Selected Agri-business Complex." Dissertation, Ph.D., Department of Vocational Agricultural Education, Louisiana State University.
- O'KELLEY, G. L., JR.**, and **LESTER, H. T., JR.**, "Characteristics of Students Enrolled in Vocational Agriculture In-school Classes in Georgia." Staff Study, Department of Agricultural Education, University of Georgia.
- O'QUINN, GEORGE DONALD**, "A Comparison of Role Concepts of Vocational Agriculture Teachers." Problem, M.Ed., Department of Agricultural Education, North Carolina State College, Raleigh.
- RUSH, WAYNE**, "Do Undergraduate Grades Accurately Predict In-service Performance of Teachers of Agriculture?" Staff Study, Department of Agricultural Education, Clemson College, Clemson, South Carolina.
- RODGERS, JOHN H.**, "Occupational Status of Students Completing a Prescribed Course in Vocational Agriculture in South Carolina 1959-63." Staff Study, Department of Agricultural Education, Clemson College, Clemson, South Carolina.
- SIEGENTHALER, IRVIN E.**, "An Investigation of Selected Factors Related to the Success of the Jimma Agricultural Technical School in Meeting Its Stated Objectives." Thesis, D.Ed., Department of Agricultural Education, Oklahoma State University.
- THOMPSON, EVANS G.**, and **STAFF**, "Pilot Training Program for Career Persons in Agriculturally Related Distributive Businesses at Wytheville, Virginia." Staff Study, Department of Agricultural Education, Virginia Polytechnic Institute.
- TUCKER, CARL B.**, "A Study of Certain Variables Associated with the Participation Behavior in Formal Voluntary Organizations of Household Heads in Three Rural Communities of Davidson County." Problem, M.Ed., Department of Agricultural Education, North Carolina State College, Raleigh.
- in a Newly Reorganized School District with Special Emphasis on Agricultural Education." Dissertation, Ph.D., Department of Education, Purdue University.
- ANDERSON, ROBERT W.**, "Development of Visual Aids in Planning Facilities for Vocational Agriculture." Colloquium, M.A., Department of Agricultural Education, University of Minnesota.
- AUNE, ARNT M.**, "A Program of Agricultural Education for the Thief River Falls Area Vocational Technical School." Colloquium, M.A., Department of Agricultural Education, University of Minnesota.
- BAKER, KENNETH**, "Preparation of Agricultural Technicians in the Area of Animal Science." Dissertation, Ph.D., Department of Agricultural Education, The Ohio State University.
- BEEKS, JOHN C.**, "Competencies in Agronomy of Freshmen in the Missouri College of Agriculture With and Without Training in Vocational Agriculture." Dissertation, D.Ed., Department of Agricultural Education, The University of Missouri.
- BENEKER, FLOYD**, "The Realization of Plans by 1957 Male Graduates in Five Selected Wisconsin Counties as Measured by a Comparison of Residential, Occupational and Educational Classification." Thesis, M.S., Department of Agricultural and Extension Education, University of Wisconsin.
- BENNETT, WILLIAM**, "Competencies in Soil Management and Use of Fertilizers Needed by Males Engaged in Farming." Thesis, M.S., Department of Education, Iowa State University of Science and Technology.
- BOEHM, CARL**, "Occupational Survey of Former Students of Vocational Agriculture at Barnesville High School Not Farming and the Implications for Improving the Program of Vocational Agriculture." Thesis, M.S., Department of Agricultural Education, The Ohio State University.
- BOLLWAHN, LESTER P.**, "Study of Needed Changes in the High School Agriculture Curriculum." Staff Study, State Curriculum Committee, Michigan State Department of Public Instruction, Lansing.
- CARLSON, KEITH**, "Competencies in Farm Credit Needed by Males Employed in Farming." Thesis,

CENTRAL REGION

Compiled by Gordon I. Swanson
University of Minnesota

ADDISON HOWARD P., "A Comparative Study of Selected Factors

- M.S., Department of Education, Iowa State University of Science and Technology.
- CLARK, R. M.**, "Competencies Needed by Workers in Non-Farm Agricultural Business and Industry." Staff Study, College of Education, Michigan State University.
- DENNISTOUN, ROLLIN**, "Some Economic Aspects of an Agricultural Machinery Leasing Program." Thesis, Ph.D., Department of Agricultural Education, University of Minnesota.
- DILLON, ROY D.**, "A Comparison of the Levels of Knowledges and Experiences Required in Two Non-Farm Agricultural Occupations." Thesis, D.Ed., Department of Agricultural Education, University of Illinois.
- EBBERT, J. MARVIN**, "The Development of a Standardized Achievement Test for Small Gasoline Engine Instruction." Dissertation, Ph.D., Department of Education, Purdue University.
- FISCUS, KEITH**, "An Analysis of Technician Knowledges Required in Selected Agricultural Occupations." Thesis, D.Ed., Department of Agricultural Education, University of Illinois.
- GRATTINGER, DENNIS**, "Competencies in Planning Cropping Systems Needed by Males Engaged in Farming." Thesis, M.S., Department of Education, Iowa State University of Science and Technology.
- GANZEL, RONALD W.**, "Farming Opportunities Expected to Become Available in the Pawnee City, Nebraska, School Service Area 1963-1973." Thesis, M.S., Department of Agricultural Education, University of Nebraska.
- HALTERMAN, JERRY**, "The Determination of Educational Needs of Agricultural Engineering Technicians in Ohio." Dissertation, Ph.D., Department of Agricultural Education, The Ohio State University.
- HAMILTON, WILLIAM**, "Competencies in Agriculture Needed by Males Employed in the Feed Industry." Thesis, M.S., Department of Education, Iowa State University of Science and Technology.
- HAWKINS, DONALD M.**, "An Evaluation and Procedure for Initiating a Dairy Herd Testing Program for Students of Vocational Agriculture." Seminar Report, M.S., Department of Agricultural and Extension Education, University of Wisconsin.
- HEDGES, LOWELL E.**, "Development of a Teaching Unit on Beautifying Home Grounds." Special Study, Department of Agricultural Education, The Ohio State University.
- HOERNER, HARRY**, "Competencies in Farm Electrification Needed by Males Engaged in Farming." Thesis, M.S., Department of Education, Iowa, State University of Science and Technology.
- HORNER, J. T.**, "An experiment to Test the Validity of Mail Questionnaires to Farmers." Staff Study, Department of Agricultural Education, University of Nebraska.
- HORNER, J. T.**, "Occupational Plans of Nebraska Farm Boys." Staff Study, Department of Agricultural Education, University of Nebraska.
- HOYT, LINDLEY**, "Competencies in Livestock Marketing Needed by Males Employed in Farming." Thesis, M.S., Department of Education, Iowa State University of Science and Technology.
- JAMES, EARL**, "History of the Soil and Water Conservation Movement in Ohio." Thesis, M.S., Department of Agricultural Education, The Ohio State University.
- JENKINS, DAVID**, "The Role of the Cooperative Extension Service in Ohio as Perceived by Members of County Extension Advisory Committees." Dissertation, Ph.D., Department of Agricultural Education, The Ohio State University.
- JONES, HOWARD**, "Follow-up of Graduates in Vocational Agriculture at the Muscoda High School." Seminar Report, M.S., Department of Agricultural and Extension Education, University of Wisconsin.
- LANG, LUKE**, "The Occupational Status of Vocational Agriculture Graduates of the Marathon High School, 1952-1963." Seminar Report, M.S., Department of Agricultural and Extension Education, University of Wisconsin.
- LANGDON, CHARLES L.**, "A Survey of Opportunities for Youth in Agriculture in Michigan." Staff Study, Agricultural Education Service, Michigan Department of Public Instruction, Lansing.
- LANDON, CHARLES L. and MERRILL, IRWIN**, "Survey of Employment Opportunities and Needed Competencies in Agricultural Occupations in Michigan." Staff Study, Michigan Agricultural Conference and the Agricultural Education Service, Department of Public Instruction, Lansing.
- LOCKWOOD, LARRY**, "Competencies in Dairy Production Needed by Males Employed in Farming." Thesis, M.S., Department of Education, Iowa State University of Science and Technology.
- MEHRER, RONALD**, "An Analysis of the Subject Matter Content of Day School Classes in Vocational Agriculture in the State of North Dakota." Thesis, M.S., North Dakota State University of Agriculture and Applied Science.
- MENGERT, FREDERICK W.**, "Developing a Program for Preparing Arlington, Ohio, High School Students for Farm-Related Occupations." Thesis, M.S., Department of Agricultural Education, The Ohio State University.
- MEYER, JAMES**, "Opportunities for Establishment of Young Men in Farming in the Ankeny Community School District." Thesis, M.S., Department of Education, Iowa State University of Science and Technology.
- MITSCHELE, WALTER**, "Competencies in Agriculture Needed by Graduates Engaged in Farm-Related Professional Occupations." Thesis, M.S., Department of Education, Iowa State University of Science and Technology.
- PARSONS, WARREN**, "Employment Opportunities and Competencies Needed for Greenhouse Workers." Thesis, D.Ed., College of Education, Michigan State University.
- PHIPPS, L. J., KREBS, A. H., HEMP, P. E., WARMBROD, J. R. and FULLER, G. R.**, "Education Regarding Cooperative Organizations in Rural Areas." Staff Study, Department of Agricultural Education, University of Illinois.
- PHIPPS, L. J., KREBS, A. H., HEMP, P. E. WARMBROD, J. R., and FULLER, G. R.**, "Illinois Agricultural Education Curriculum Research Project." Staff Study, Department of Agricultural Education, University of Illinois.
- RICHTER, ALEXANDER**, "Factors Influencing College Dropout of the 1957 High School Freshmen of Five Selected Wisconsin Counties." Thesis, M.S., Department of Agricultural and Extension Education, University of Wisconsin.
- ROBINSON, NORMAN**, "Competencies in Machinery Maintenance Needed by Males Employed in Farming." Thesis, M.S., Department of Education, Iowa State Uni-

- versity of Science and Technology.
- RIDENOUR, HARLAN E.**, "Suggestions of Ohio Teachers on Needed Curriculum Materials." Special Study, Department of Agricultural Education, The Ohio State University.
- ROSS, LYLE**, "A Study of Time Devoted to the Mechanics of Record Keeping by Selected Farmers in the Southwestern Farm Management Service." Colloquium, M.A., Department of Agricultural Education, University of Minnesota.
- RUTH, WILLIAM**, "Factors Affecting Vocational Choices of Graduates in Agricultural Education from 1948 to 1958." Thesis, M.S., Department of Agricultural Education, The Ohio State University.
- SCADDEN, EDWARD R.**, "Occupations of Former Vocational Agriculture Students of Blanchardville High School, 1949-1963." Seminar Report, M.S., Department of Agricultural and Extension Education, University of Wisconsin.
- SCHIED, DANIEL W.**, "The Occupational Trends of Graduates of Fort Atkinson High School Vocational Agriculture Department as Compared with Dropouts During the 1950-1963 Period." Seminar Report, M.S., Department of Agricultural and Extension Education, University of Wisconsin.
- SIMEK, MELVIN**, "A Study of the Image of Vocational Education in South Dakota Schools." Thesis, M.S., Department of Agricultural Education, South Dakota State College of Agriculture and Mechanic Arts.
- SINHA, HARISHANKER P.**, "Development of Agricultural Education in India." Dissertation, Ph.D., Department of Agricultural Education, University of Missouri.
- SORENSEN, FRED A.**, "A Procedure for Teaching Comparative Crop Enterprise Analysis in the Farm Management Program." Colloquium, M.A., Department of Agricultural Education, University of Minnesota.
- STEVENS, ANDREW**, "The Use of Farm Publications by Ohio Teachers of Vocational Agriculture." Thesis, M.S., Department of Agricultural Education, The Ohio State University.
- TESKE, PHILIP R.**, "A Study of the Teaching Load of Indiana Vocational Agricultural Instructors." Staff Study, Department of Education, Purdue University.
- TIMMONS, GUY E.**, "A Study of Mechanical Jobs Performed by Selected Farmers in Michigan." Staff Study, College of Education, Michigan State University.
- TODD, HOLLIS E.**, "Role Perception As Related to Difficulties Experienced by Beginning Teachers of Vocational Agriculture." Thesis, Ph.D., Department of Agricultural Education, The Ohio State University.
- VAN LOH, FRED**, "Competencies in Agriculture Needed by Males Employed in Retail Fertilizer Distribution." Thesis, M.S., Department of Education, Iowa State University of Science and Technology.
- WALTERS, DONALD**, "How Young Farmers in the Ripon, Wisconsin, Area Have Become Established in Farming." Seminar Report, M.S., Department of Agricultural and Extension Education, University of Wisconsin.
- WARD, REYNOLD**, "A Five Year Study of Farm Accidents in Minnesota as a Basis for Curriculum Content in a Vo-Ag Program." Colloquium, M.A., Department of Agricultural Education, University of Minnesota.
- WEBER, ALTON H.**, "A Proposed Agricultural Science Curriculum for Seventh Grade Students." Thesis, M.S., Department of Agricultural and Extension Education, University of Wisconsin.
- WOTOWIEC, PETER**, "Development of an Adult Education Program in Vocational Horticulture for Greater Cleveland." Thesis, M.S., Department of Agricultural Education, The Ohio State University.
- YOUNGMAN, CHARLES**, "An Analysis of the Training Needs of Ohio County Extension Agents in the Use of Television as an Educational Medium." Thesis, M.S., Department of Agricultural Education, The Ohio State University.
- Farmer Classes." Master's Report, M.E., Department of Vocational Education, Colorado State University.**
- MABE, DAN**, "Factors Influencing the Development of Supervised Farming Programs of Students in Idaho." Master's Report, M.E., Department of Vocational Education, Colorado State University.
- WAGNER, GERALD**, "Economic Importance of Agricultural Skills in Selected Enterprises in North Dakota." Master's Report, M.E., Department of Vocational Education, Colorado State University.
- JUERGENSON, E. M.**, "Career Choices by Agriculture Students in Selected High Schools—1962—1967." Staff study, Department of Agricultural Education, University of California, Davis.
- THOMPSON, O. E.**, "Characteristics of Freshman Students Enrolled in the College of Agriculture, University of California, Davis." Staff study, Department of Agricultural Education, University of California, Davis.
- THOMPSON, O. E.**, "Values of High School Students and Their Teachers." Staff study, Department of Agricultural Education, University of California, Davis.
- REGAN, MARY C.**, "Study of Intellectual and Motivational Characteristics of Students at University of California, Davis." Staff study, Department of Agricultural Education, University of California, Davis. □

Good Relationships . . .

(Continued from page 71)

uate the teacher on the basis of what he does as well as on the things he fails to do. Some things the teacher may do which command respect and favorable attitudes of students include: being fair and impartial, being considerate, being punctual, being well informed, being interested in students as individuals, keeping things told in confidence, and requiring high standards of workmanship.

Community Relations

Assistance from others throughout the community can be most useful to the teacher in the conduct of the program in agriculture. Cooperation is a two-way road which indicates that we must give if we expect much help. A number of factors influence the degree of cooperation received.

PACIFIC REGION

Compiled by J. D. McComas
New Mexico State University

- SANSTEDT, NEIL R.**, "Dropouts in Agriculture at the Northeastern Junior College." Master's Report, M.E., Department of Vocational Education, Colorado State University.
- ANDERSON, ARLYNN D.**, "Opportunities for Entry into Farming." Report, M.E., Department of Vocational Education, Colorado State University.
- ANDERSON, ROBERT L.**, "Factors Influencing Attendance in Adult

For example, most persons appreciate someone showing a genuine interest in them as individuals and also in their major activities and problems. By being concerned about others and lending a sympathetic ear for a few moments the teacher may influence a member of the community.

Evidencing an interest and a concern for the civic affairs of the community will be noted by civic minded individuals. Participation in programs of community betterment are usually appreciated also.

Other factors influencing the attitudes of the community include hard work, doing a job well, being forthright and honest, and following the principle of the Golden Rule.

Teachers can be forceful community leaders only to the degree that they eliminate the barriers to good school-community relationships. It is only human that problems arise. The methods used in solving these problems and reducing their incidence will determine the effectiveness of the teacher and the community program of agricultural education. □

Add Horticulture . . .

(Continued from page 64)

4. *Seasonal Labor Needs of Industry.* Many horticulture trades are quite seasonal in nature and as a result their labor requirements are the same. Oftentimes this is the reason why cooperators are hard to locate. It also creates a problem in scheduling students for on the job experience.

5. *Development of a course of study.* A builder cannot construct without a blueprint; a traveler cannot make a sensible journey without a map; just so an educational program cannot achieve its desired end unless it has a plotted course to follow. The development of an appropriate course of study is probably one of the most neglected duties of teachers because of the tremendous work involved. The lack of such can nullify everything which has preceded it.

In summary then, consider the possibility of supplementing your program with a class or two of ornamental horticulture. If you feel that this is possible, keep the following points in mind as you proceed:

1. Study the educational needs and employment opportunities in your community
2. Develop a course of study to fulfill these goals

3. Set up an advisory committee
4. Select cooperators
5. Obtain needed facilities. Even industrial facilities
6. Good communication between you, administration and co-operators □

Changes in Editing-Managing Board

Dr. R. J. Agan, Chairman, Depart-

ment of Agricultural Education, Kansas State University, became Chairman of the Editing-Managing Board July 1, 1964, succeeding Cola D. Watson, State Supervisor of Vermont. A new member of the board as of July 1, 1964 is Dr. David McClay, Chairman of the Department of Agriculture of the Pennsylvania State University, representing the Atlantic Region.

Now Here's an Idea

DON W. BROCK, Teacher of Vocational Agriculture, Topeka, Kansas

A Holding Table for Calves

Here's an idea which I picked up in visiting with Ralph Moser of Texas. Steel wagon wheel tires form the base for a table which simplifies the handling of calves. The table permits the handler to place the calf on the table and roll him over so that he is lying flat at approximately table height.

Wagon tires are cut in one place and ends are spread to a distance of approximately 54" to form a horse-shoe shaped figure. The open end of the horseshoe is closed by welding a piece of angle iron across the opening. These closed horse shoes are set up on edge approximately 6' apart. Two inch boards are bolted onto the flat side of the horseshoe which forms the table with a semi-circular leg on each end. Near the edge at each end of the table surface,

securely fasten one end of a heavy strap of suitable length.

In operation, the device is rolled over so that the table is actually lying on its side. This puts the flat table surface perpendicular to the ground. The animal is moved up to a position in which he is standing against and parallel to this flat surface. For animals that are not broken to lead, the table may be placed near another flat surface such as a board fence or the side of a building, with panels arranged to funnel the animals into the space between the two flat surfaces. Throw the straps over the animal's back and pass them under his body and pull them tight at the fore and rear flanks. This will secure the calf to the table. The table is then rolled over which lifts the calf off the ground and places him in a flat position where attention can be given to whatever treatment is required. □

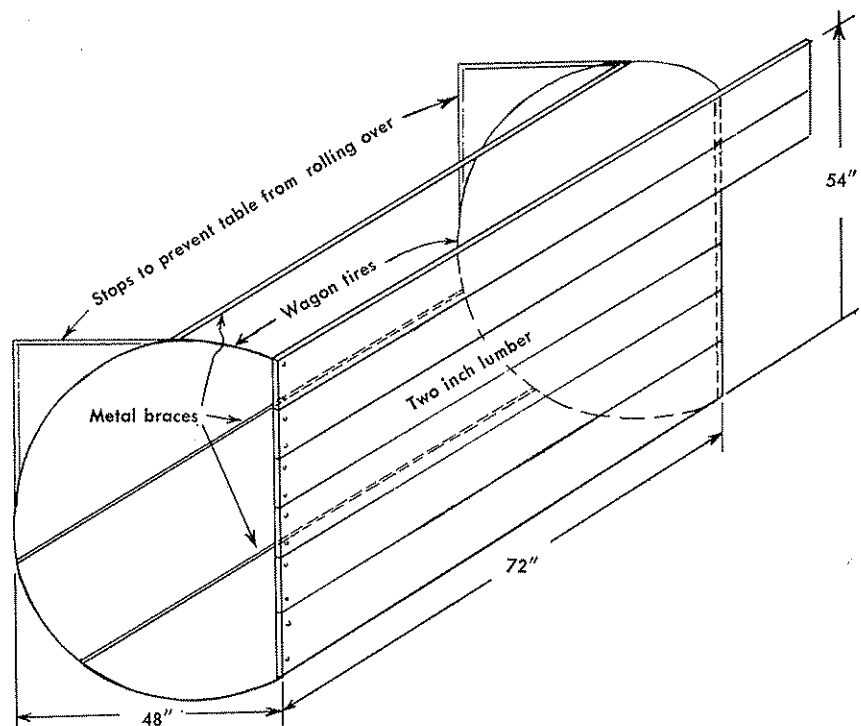



N.V.A.T.A. News

James Wall
Executive
Secretary

The Future Farmer Supply Service will soon offer a new blazer type jacket for chapter advisors. The jacket will be blue and can be secured with an embroidered gold patch of an owl or the NVATA emblem. The word "Advisor" will not appear on the jacket. The jacket is being offered in response to many requests from NVATA members for a more dressy and suitable jacket in place of the regular FFA Advisors jacket.

The First NVATA General Session of the National Convention to be held at Minneapolis, Minnesota, is scheduled for 10:00 A.M. on Saturday, December 5. The Second General Session will be at 1:00 P.M. on Sunday and the Final General Session will begin at 9:45 A.M. on Wednesday.

Regional meetings will be held Saturday afternoon and Monday morning. There will also be a number of group meetings and special activities for NVATA members and their wives.

Many interesting meetings are being arranged for the combined Agricultural Education Groups including such topics as—"Opportunities in the Area School and Community College," "Opportunities in Farming," "Opportunities in Agricultural Related Occupations Through the FFA" and "Opportunities in Agriculture, A Realistic Approach Through Guidance."

A new brochure entitled "Student Information Bulletin" is now available for teacher education departments. It can be secured free of charge by teacher educators desiring material to use in teaching the need for and importance of professional organizations. Requests should be addressed to—James Wall, Executive Secretary, NVATA, Box 4498, Lincoln, Nebraska 68504.

The NVATA will sponsor two "Coffee Hours" during the National FFA Convention. All are invited to attend the "Coffee" scheduled especially for them. Student teachers and teacher educators are urged to be present for the affair planned for their group. Announcement of the location and time for both events will be made at the convention.

News and Views of the Profession

Dr. John C. Floyd

Dr. John Claiborne Floyd, Professor of Agricultural Education, Louisiana State University and Mechanical College passed away on June 7, 1964.

Dr. Floyd has served in the system of Public Education of Louisiana for 44 years, 43 of which have been in the field of agricultural education, and 33 of the years at Louisiana State University.

He served his country in foreign service in both World War I and II, retiring from the army with rank of captain. In collegiate athletics he lettered in both football and baseball.

He holds membership in many professional associations and was a life member of the American Vocational Association.

He recently retired from duty at Louisiana State University.

Dr. Victor E. Nylin

Dr. Victor E. Nylin, chairman of the department of agriculture at the Wisconsin State College at Platteville, died suddenly on May 6th.

Dr. Nylin, a native of Minnesota, received his M.D. Degree from the University of Minnesota in 1925 and his Ph.D. in 1937. He taught vocational agriculture and was critic teacher at the University of Minnesota from 1921-1938. He joined the faculty of the Wisconsin State College at Platteville as instructor in Agriculture and Biological Science in 1938 and was appointed Director in 1941.

Dr. Bjarne S. Ullsvik, President of the State College, said upon his death: "Dr. Nylin has been a loyal and devoted member of the staff. Hundreds of graduates from the agriculture department of this college will mourn his passing and the science of agriculture has suffered a great loss."

PERSONALS

Professors Warren G. Kelly and Claude McGhee are on leave of absence from the Agricultural Education Dept. at Morgantown, West Virginia while working toward doctorates.

Dr. Harry W. Kitts, teacher educator of The University of Minnesota, has just returned from a two-year assignment in Thailand.

Dr. Leon W. Boucher, teacher educator of the Ohio State University, left August 13 for a two-year assignment in Bhubaneswar, India, as a specialist in Agricultural Education.

Dr. Raymond M. Clark was advanced from associate professor to professor of agricultural education July, 1964 at Michigan State University, East Lansing, Mich.

Roland Peterson, vocational agriculture teacher at Hooper, Nebraska, for 3 years, was appointed to the State Supervisory staff as area consultant July 1, 1963, Lincoln, Nebraska.

Dr. A. H. Krebs was advanced from associate professor to professor September, 1964, in the Agricultural Education division, University of Illinois, Urbana, Illinois.

Gerald R. Fuller was advanced from instructor to assistant professor September, 1964, in the Agricultural Education division, University of Illinois, Urbana, Illinois.



Frank W. Adams (right) takes a look at a plaque on which his name has been engraved as the Outstanding Arizona Teacher of Vocational Agriculture for the Year. This award was made by Raleigh A. Jobs (left), president of the University chapter of Alpha Tau Alpha, the National Professional Fraternity in Agricultural Education. The annual selection of the outstanding teacher of agriculture is made by teachers in Arizona who are members of Alpha Tau Alpha. The award is based upon the candidate's scholarship, leadership, professional accomplishments and service to the teaching profession. Mr. Adams who is completing his eighth year as a teacher of vocational agriculture at Douglas High School is currently president of the Arizona Vocational Agriculture Teachers Association.

Stories in Pictures

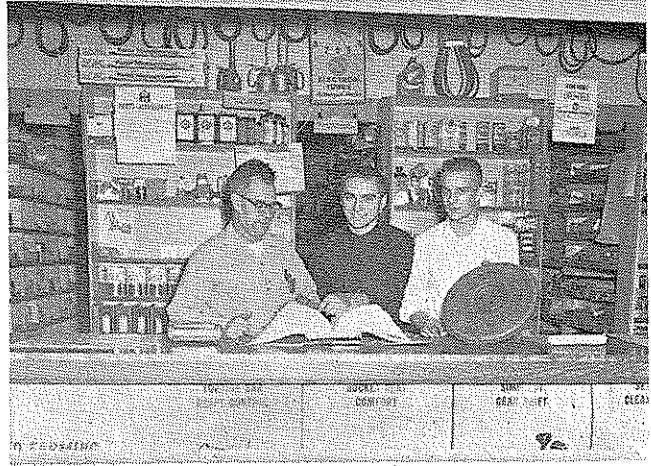

Joe Thomas, manager of the local International Harvester store at Fairview, Montana, counsels with vocational agriculture business students placed for partsmen experience. Tom Miller (center), and Carl Christiansen (right), have taken three years of vocational agriculture before enrolling in agriculture-business.



JAMES K. BAKER, graduate student in agricultural education at Ohio State University, begins a class presentation using a series of charts which will be presented with an overhead projector.



A larger part of the student's occupational experience must be provided at the large city school. Here Vincent Feck of Cleveland, Ohio supervises the planting of annuals by two of his students on the grounds of West Technical High School.



Dr. Joe P. Bail (right), Chairman of the Department of Agricultural Education, Cornell University, receiving a certificate of honorary membership in the Phi Chapter of Alpha Tau Alpha at the University of Arizona. Raleigh A. Jobes III, Chapter President, made the award. On sabbatical leave from his institution last semester, Dr. Bail served as Visiting Research Professor at the University of Arizona where he conducted a study of the state program of Agricultural Education at the high school level sponsored by the Department of Agricultural Education and the State Department of Vocational Education.



Ornamental horticulture was the subject of this graduate seminar conducted by the Department of Agricultural Education at Fremont, Ohio last spring. The ten session seminar enrolled 16 Vo-Ag teachers and 4 Agricultural Extension Agents.