

The

Agricultural Education

November 1985
Volume 58
Number 5

Magazine

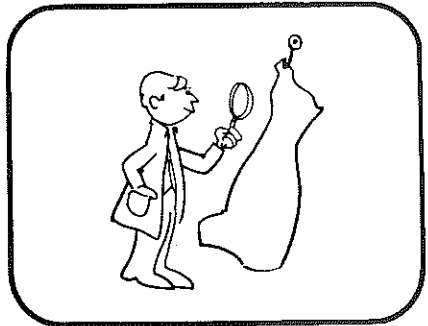
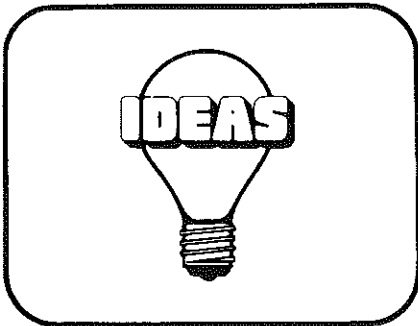
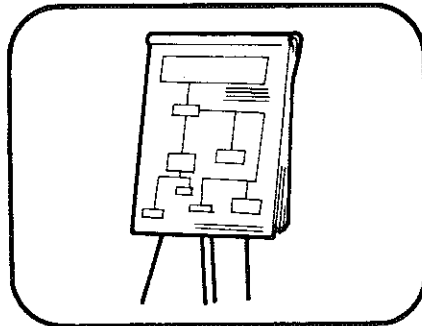
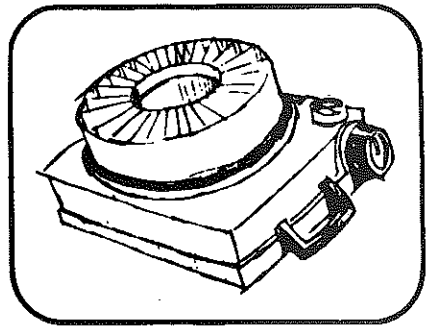
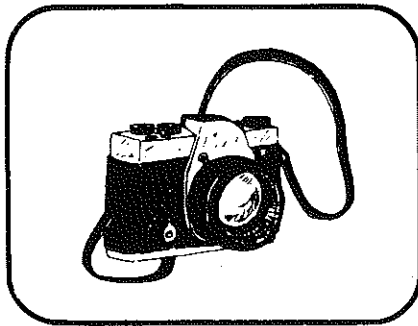
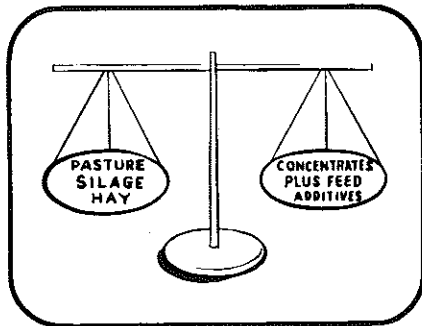

THEME: Teaching Tips

007653 1285
DR. FLOYD G. MCCORMICK
UNIV. OF ARIZ.
6933 PASEO SAN ANDRES
TUCSON AZ 85710



Professional Thanksgiving

November, 1985

Volume 58

Number 5

MANAGING EDITORS

Editor
 LARRY E. MILLER, Ohio State University, 2120 Fyffe Road, 204 Ag. Adm. Bldg., Columbus, Ohio 43210

Business Manager
 GLENN A. ANDERSON, 1803 Rural Point Road, Mechanicsville, VA 23111

Consulting Editor
 JASPER S. LEE, P.O. Drawer AV, Mississippi State, MS 39762

REGIONAL EDITORS

North Atlantic Region
 ELMER COOPER, Department of Ag. & Ext. Education, University of Maryland, College Park, MD 20742

Southern Region
 LARRY R. ARRINGTON, Dept. of Ag. & Ext. Education, 305 Rolfs Hall, University of Florida, Gainesville, FL 32601

Central Region
 GEORGE WARDLOW, Division of Agricultural Education, 320 Vocational and Technical Education Building, University of Minnesota, St. Paul, MN 55108

Pacific Region
 JOHN MUNDT, State Supervisor, Agri. Educ., Len B. Jordan Bldg., Rm. 325, 650 West State Street, Boise, ID 83720

SPECIAL EDITORS

Book Review Editor
 LONELL MOELLER, Agri. Ed., Division of Educ., Box 2220, South Dakota State University, Brookings, SD 57007

Teaching Tips Editor
 LOWELL E. HEDGES, Dept. of Ag. Educ., 204 Ag. Adm. Bldg., 2120 Fyffe Road, Ohio State University, Columbus, OH 43210

Picture Editor
 ROGER D. ROEDIGER, Curriculum Materials Service, 254 Ag. Adm. Bldg., 2120 Fyffe Road, Ohio State University, Columbus, OH 43210

EDITING-MANAGING BOARD

Chairman
 Jim Cummins, Ohio Department of Education

Vice Chairman
 Douglas Pals, Teacher Education, Moscow, Idaho

Secretary
 Jasper S. Lee, Mississippi State University

Editor
 Larry E. Miller, The Ohio State University

Members
 Glenn A. Anderson, Virginia Department of Education
 Larry Case, U.S. Department of Education
 Sam Stenzel, NVATA, Alexandria, VA
 Duane L. Watkins, NVATA, Thermopolis, WY
 E. Craig Wiget, NVATA, Mt. Blanchard, OH
 Curtis Corbin, Jr., Georgia Department of Education
 Supervisor from North-Atlantic Region
 Myron Sonne, NVATA, Letcher, SD

Table of Contents

	Page
Editor's Page	
Professional Thanksgiving Larry E. Miller	3
Theme: Teaching Tips	
Teaching Tips: For What Purpose? Lowell E. Hedges	4
Audio Visual Materials: A Key to Increasing Teacher Effectiveness Larry Kirk and George C. Hill	5
A Potpourri of Tips Jeff Rotering	8
Storage: Today's Project Marlin Seeman	9
Six Tips for Using Problem Solving John R. Crunkilton	10
Ideas From Florida Larry R. Arrington	12
Ohio Emeriti Share Tips Odell C. Miller	13
. Gilbert S. Guiler	13
. Leon W. Boucher	13
. Ralph E. Bender	13
. Robert W. McCormick	14
. Richard H. Wilson	14
. Ralph J. Woodin	14
. Paul F. Pulse	15
Techniques for Motivating Students in SOEPs Elmer L. Cooper	15
Improving Visual Communications Cliff McClain and Jack Prince	17
An Engine Valve Display Richard S. Schertz	18
Computer Print-Out for Stencils David L. Mooring	19
Wheel Alignment for a Tractor Axle Jim Cooney	20
Classroom Check List Cynthia M.A. Higgins	21
Spur Key Ring Larry Nickerson	22
Names of Plants Robert G. Keenan	23
Stories in Pictures	24

ARTICLE SUBMISSION

Articles and photographs should be submitted to the Editor, Regional Editors, or Special Editors. Items to be considered for publication should be submitted at least 90 days prior to the date of issue intended for the article or photograph. All submissions will be acknowledged by the Editor. No items are returned unless accompanied by a written request. Articles should be typed, double-spaced, and include information about the author(s). Two copies of articles should be submitted. A recent photograph should accompany an article unless one is on file with the Editor.

PUBLICATION INFORMATION

THE AGRICULTURAL EDUCATION MAGAZINE (ISSN 0002-144X) is the monthly professional journal of agricultural education. The journal is published by THE AGRICULTURAL EDUCATION MAGAZINE, INC., and is printed at M & D Printing Co., 616 Second Street, Henry, IL 61537.

Second class postage paid at Mechanicsville, VA 23111; additional entry at Henry, IL 61537.

POSTMASTERS: Send Form 3579 to Glenn A. Anderson, Business Manager, 1803 Rural Point Road, Mechanicsville, Virginia 23111.

SUBSCRIPTIONS

Subscription prices for THE AGRICULTURAL EDUCATION MAGAZINE are \$7 per year. Foreign subscriptions are \$10 (U.S. Currency) per year for surface mail, and \$20 (U.S. Currency) airmail (except Canada). Student subscriptions in groups (one address) are \$4 for eight issues. Single copies and back issues less than ten years old are available at \$1 each. All back issues are available on microfilm from Xerox University Microfilms, 300 North Zeeb Road, Ann Arbor, MI 48106. In submitting subscriptions, designate new or renewal and address including ZIP code. Send all subscriptions and requests for hardcopy back issues to the Business Manager: Glenn A. Anderson, Business Manager, 1803 Rural Point Road, Mechanicsville, VA 23111. Publication No. 07324677.

This month inevitably brings to mind thoughts related to giving thanks. Thanksgiving Day typically focuses one's thoughts upon those things related to our family, our personal welfare and our great country for which we should be thankful. The professional side of one's life also brings many things for which we should be thankful.

We should be thankful that we were born and live in a country with such opulent natural resources and such an ideal climate and topography as to be able to support our people in such an affluent fashion. Those in other areas of the world, such as Ethiopia, have not been so endowed.

The populace and the governments of this nation have seen fit to support an educational system that is unrivaled worldwide in its quest to provide an education for everyone. We are fortunate in that people realize the importance of the study of agriculture in order that we may learn to conserve our resources as we produce food, fiber, shelter and aesthetic materials. When the priority of our program is not as high as we would wish, we, no doubt, experience frustrations, but thankful we should remain because we continue to have the opportunity to teach and serve.

Support Services

We should be thankful for all those thousands of people who directly support us. The state departments of education who help certify us, supervise us, administer to/for us, financially support us, and provide numerous other services. Similar support exists at the national level.

The colleges and universities that trained us and continue to minister to our professional and technical development needs are due praise. Numerous members of the faculties in colleges of agriculture and education continually strive to fulfill our wants and needs. The researchers, the administrators, and the clerical staffs all diligently pursue continuous efforts to aid us.

At the local level, most are blessed with caring administrators, support staff and teaching colleagues who greatly contribute to our ability to deliver a program of high quality. Thousands of alumni, and others just as concerned and supportive, provide innumerable services and encouragement.

The people in these support services are ones who make our jobs meaningful. These people care and they want to help. Oh, we sometimes face indifference, but that is rarely the case. Most often, we can rely upon people to perform their responsibilities in not only a professional manner, but in a way that makes life enjoyable.



By LARRY E. MILLER, EDITOR
 (Dr. Miller is a Professor in the Department of Agricultural Education at The Ohio State University.)

The Clientele

The students we serve are another group for which we should be thankful. "Thankful for my students, you say?" Yes, of course, you should be. And you know, best of all, why. Teachers who do not literally love their students are typically not in the profession for long.

Of course, students come to us with different aptitudes, abilities, personalities and idiosyncrasies; but each and every one is important to us. Where and what would we be without the twinkling eyes, the inquiring minds, the teasing banter, or the mischievous stunts. They make the job worth doing, the profession challenging, and the life fulfilling.

Whether our students are adolescents or adults, they bring us new challenges. They keep us intellectually active. Few professions which deal with people become boring because of trite routines, and ours is certainly no exception. Each student stimulates us to reach beyond ourselves and thus we continue to grow. Our job may have routine paper work and repetitious activities, but no two days are ever the same. Each day can bring joy, happiness and satisfaction.

A trademark of our profession has been the ability to take students from where they are in current ability and understanding to new, higher levels. Satisfaction often results from those that attain a high honor such as an American Farmer degree in FFA or a state office, but satisfaction also results from helping those less capable achieve specific goals. Yes, we should be thankful for them all. They are our product and are indelibly stamped by their teachers of vocational agriculture.

This Issue

Teaching tips are provided in this issue to help create that sparkle in the eye, that look of understanding, and that need to know. Numerous ideas and strategies are proposed by colleagues and peers in the hope of providing you with some helpful ideas to stimulate, motivate and improve instruction.

Teaching Tips: For What Purpose?

At the heart of teaching and learning is communication. Any factors that interfere with the process of communication impedes the teaching and learning processes. Conversely, factors that enhance communication help ensure effective teaching and learning. Teaching tips, as presented in this issue of *THE AGRICULTURAL EDUCATION MAGAZINE*, can help ensure effective communication by (1) capturing the interest and attention of students, (2) making principles and concepts easier to understand, (3) providing purposeful, credible and acceptable experiences for the student, and (4) reinforcing learning through commonly understood concepts, happenings and symbols.

What are teaching tips? Teachers commonly consider as teaching tips such things as audio-visual materials, teacher/student activities, teaching philosophies, teaching techniques or strategies, group management techniques, as well as evaluation procedures (Wiman and Meierhenry, 1969).

Communication Process

What is the communication process? Kemp (1980) illustrates it with this sequential diagram. As we move along the communication process, we can readily see where various types of teaching tips can contribute to the implementation of the process.

Kemp's model illustrates that communication starts with a message. The message originates in the brain of an individual, who is the source or sender. The message is encoded, or transformed into a signal suitable for transmission. The signal, or form of transmission, is a thought changed into words by being turned into sound waves or words of script. The message, whatever it might be, then passes through a transmitter, which can be print, film, or television, via a suitable channel, such as wire, air, paper, and/or light. The message then goes to the receiver, where the signal is reconstructed into a message. The signal gets inside the receiver (learner or student in the context of this article) through the body's sensory receptors (eyes, ears, nose, mouth, touch). These are the pathways to the receiver's (learner's or student's) mind, the destination of the message and where learning occurs. It is within the central nervous system that the message is decoded, or converted into mental symbols.

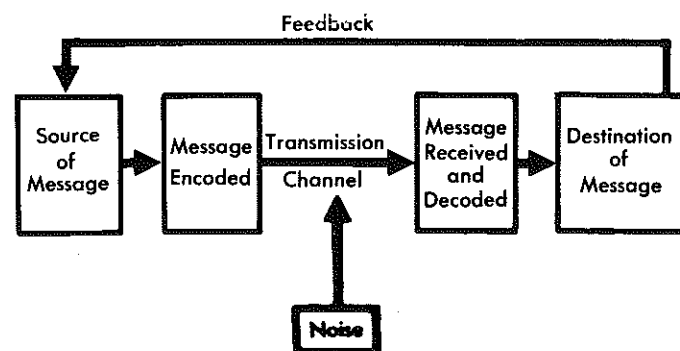

By LOWELL E. HEDGES, THEME EDITOR

(Editor's Note: Dr. Hedges is an Associate Professor in the Department of Agricultural Education at The Ohio State University, Columbus, Ohio 43210-1099.)

Effective communication is a two-way process. The receiver or learner must be active. Activity is evidenced by the receiver (student) answering, questioning, or performing, mentally or physically. This response of the receiver (student) is referred to as feedback. Feedback enables the sender (teacher, in this example) to improve, if necessary, the transmitted message, the encoding and transmission processes, or to assist the receiver in decoding the message (giving the message a meaning).

An impedence (restricting, slowing down, or stopping) to the communication process, and ultimately to the teaching and learning processes, is the element referred to as "noise". Noise is any disturbance that prevents accurate transmission of the message, or reception and perception of the message by the receiver (student). Noise, in the context of the communication process, can be sound, light, past experiences, or lack of attention on the part of the student due to physical and psychological conditions. Noise can be ineffective activities on the part of the teacher, such as the use of unclear illustrations, a limited number of clarifying examples, too rapid of a teaching pace, poor quality visuals, and an uncomfortable physical environment.

Aiding Communication

How can teaching tips help overcome noise in the communication process? For example, they can help eliminate or reduce noise in the communication process that may occur at the start of the process — the message itself. Communication (and ultimately learning) cannot take place without a message, or stimulus. No learning can take place without "something" to get it started, whether it is an event or fact or symbol. That "something" is referred to as a stimulus. Spoken and written words, pictures, and all audio-visuals are examples of stimuli. Stimuli vary in quantity and quality, and can be manipulated by the teacher. Of the two, quality has the greater effect on the learning process. Anything that the teacher does to restrict either quantity or quality of the stimuli, the teacher is impeding learning. The use of "teaching tips" is a means of providing high quality stimuli to the learner (Frymier, 1965).

Sometimes noise can prevent the learner from receiving the message sent by the teacher. If this is the case, ap-

propriate teaching tips can aid in the reception of the message. The stimuli must get inside the learner if they are going to have an effect on learning. Stimuli enter, or are received, by the body's sensory receptors (eyes, ears, nose, mouth, touch) which are the pathways to the learner's minds, where learning occurs. Improperly functioning receptors cause impedence of stimuli, thus restricting learning. Many times, a teaching tip can help overcome the impedence of improperly functioning receptors.

Many appropriate teaching tips can overcome internal noise within the receiver, or student. If the receiver (students) gives evidence of lack of attention, a different interest approach in the lesson can be used. A tip that aids the teacher in utilizing principles of learning may capture the student's interest. Through the use of teaching tips, the skillful teacher presents problems, experiences and activities which serve to spark the enthusiasm of the learner to learn what the teacher wants to teach.

Another noise may be conflicting past experiences of the student. The meaning of the message has to come from the receiver (student). The meaning is based on the learner's past experiences. The experiences may be such that they prevent the learner from perceiving the message correctly within the context of the lesson.

Physical conditions (e.g., brain damage, environmental stress) and psychological conditions (e.g., low self-esteem, a real or imagined threat, values held, personal needs) can prevent the learner from giving the correct meaning to a stimulus. Appropriate teaching tips can help remove or overcome the many possible conditions that impede correct perception of stimuli.

Interference with the communication process may occur in the feedback portion. Acting on perceptions and testing out personal meanings through behavior is where learning

shows. The learner must discover if proper meaning was given to the message (stimulus). If learners are denied the opportunity to explore or act upon their perceptions, or if they are induced to react in some undesirable way, then learning will also be affected at this point. An appropriate procedure or setting provided by a teaching tip may be the needed assistance required by learners to appropriately act on their perceptions of the message (stimulus).

What is the purpose of teaching tips? The purpose lies within the definition of teaching. A definition common to the profession is that "teaching is directing the learning process". In other words, the role of the teacher is conceived as one which organizes and provides essential learning experiences for students. The process of learning does not occur until the learner interacts and becomes involved in the experiences provided by the teacher.

Teaching, according to our definition above, implies communication; the means of transmitting that which has been learned (or is in possession of the message) by one learner to another. Proficient teaching relies upon communication as its vehicle for success.

The function of the teaching tips included in this issue of *THE AGRICULTURAL EDUCATION MAGAZINE* is to affect the success of the teacher's efforts to communicate effectively.

References

- Frymier, Jack R. *A NATURE OF EDUCATIONAL METHOD*. Columbus, Ohio: Charles Merrill Books, Inc., 1965.
- Kemp, Jerrold E. *PLANNING & PRODUCING AUDIOVISUAL MATERIALS*. 4th Ed., New York: Harper & Row, Publishers, 1980.
- Wiman, Raymond V. and Meierhenry, Wesley C., (editors). *EDUCATIONAL MEDIA: THEORY INTO PRACTICE*. Columbus, Ohio: Charles E. Merrill Publishing Company, 1969.

Audio-Visual Materials: A Key to Increasing Teacher Effectiveness

Audio-visual aids have long been used in the teaching of vocational agriculture. The use of visuals often detracts from the overall presentation. In fact, poor quality visuals often undermine a teacher's instructional effectiveness.

One purpose of this article is to offer tips in using audio-visual aids in order to improve the quality of information transfer in the classroom or laboratory. Because the subject is broad and encompasses many disciplines, the focus of this article will be on types of audio-visual aids that teachers can create, such as overhead transparencies, slides, models, and graphic art materials. A second purpose is to present practical ideas that can be applied and used to your advantage in the classroom.

Preparation Tips

Teachers can easily alter existing lesson plans to include a variety of audio-visuals. The time and cost involved in
(Continued on Page 6)

NOVEMBER, 1985



By LARRY KIRK AND GEORGE C. HILL

(Editor's Note: Mr. Kirk is an Extension Editor and Associate Professor and Dr. Hill is in the Department of Agricultural Education and Communications at the University of Nevada, Reno, Nevada 89507.)



Many newer slide projectors have audio functions that will allow for soundtracks and narration as well as automatic advancement to be incorporated into slide presentation.

(Continued from Page 5)

adding these teaching aids is relatively minor. There are as many uses of audio-visuals as your talent or imagination can create. The use of these techniques can enhance overall teaching effectiveness and help to achieve educational goals.

Slide Presentations

Slide presentations are useful in introducing a new topic. They can be very effective when inclement weather prevents outdoor activities. Slides are also appropriate in comparing and contrasting items being discussed.

Two factors are crucial in the preparation of high quality slide shows. First, decide what factors you want to emphasize. Develop a detailed outline and revise it as you prepare the presentation. Second, determine whether it is appropriate to record the audio or narrate the slides during each presentation.

Many new projectors are available with audio features. You can increase the effectiveness of the presentation by taking the time to add audio features. If a decision is made to record the narration, make arrangements to move the microphone a distance from the projector. Nothing ruins a slide show faster than amplified fan noise. Audio tracks with music and sound effects should be completed in an audio production center where you have access to proper



Models can be excellent teaching tools when used properly.

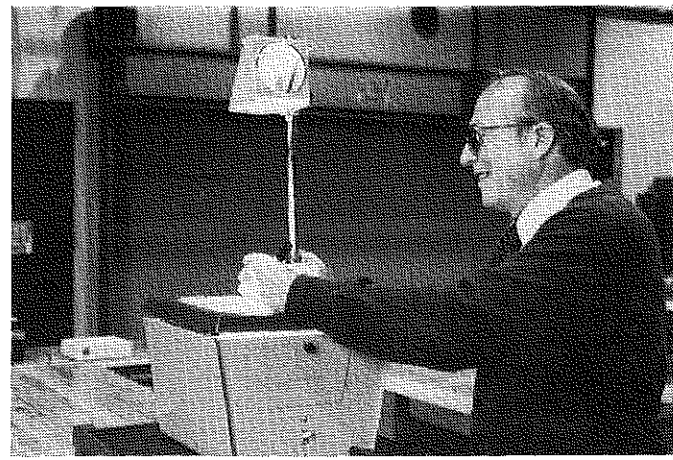

Using audio-visual equipment effectively can increase the teacher's effectiveness.

equipment. If you program the show with tape, make sure you know where to trip the tones on the tape ahead of time. Complete concentration is required when inserting trip tones, so a quiet location with no interruptions is vital.

There are several important techniques for automating slide presentations. Before beginning the process, you need to decide if automation of your slides will actually enhance your presentation. If you decide that sound effects, voices, and music will help achieve your goal, organization is of vital importance.

The following steps are helpful in preparing well organized slide shows:

1. Prepare a script with the points you wish to cover. Never allow the presentation to exceed 20 minutes. Make it shorter if possible, as this type of presentation is best digested in small segments.
2. Shoot and select slides which fit the script of your show. When taking slides, remember that professional photographers usually take large numbers of slides to get just one print. Do not try to cut costs by limiting yourself to a small amount of film.
3. Put a blank, darkened slide before and after the program to avoid sudden bursts of light which can blind, distract, or even alienate your students.
4. Record the audio track. It may take several attempts before you are satisfied with a product.

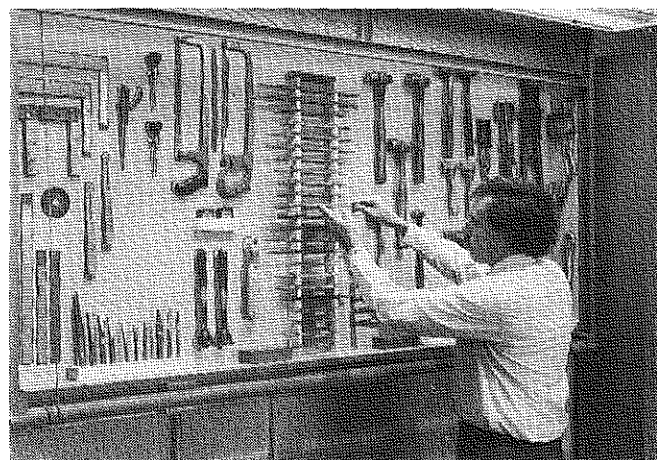

A well organized tool cabinet is an excellent resource for the effective teacher.

5. Put trip tones for slide advancement on the audio tape. The use of a high quality tape programmer will make your slide show much more professional in appearance.

In summary, slide presentations can be a very effective teaching tool when carefully planned and developed. Instructors who develop good quality slide presentations will greatly increase their teaching effectiveness.

Overhead Transparencies

The typical audio-visual overhead transparency too often consists of a page of typing. Unfortunately, these transparencies are hard to read and even harder to follow. In a sense, it is information overkill. All too often students fail to observe key points that the instructor intends to achieve even if the transparency is legible.

Transparencies developed by teachers can be very effective teaching tools or they can be so distracting that the whole purpose of the lesson is lost. Many times transparencies developed by teachers are of such poor quality that they are worse than a dittoed handout. Self-developed transparencies that are neat, attractive, and legible are always more effective. Good transparencies generally incorporate the use of graphics. If you are going to use a transparency that is simply printed information, why not make copies for all students and forget the transparency? It will save both the teacher and students considerable time.

There is nothing wrong with using large type or lettering devices to improve the legibility of transparencies, particularly if they are the kinds that will receive heavy use. Many of the newer electronic typewriters have large-type elements. Most schools have some type of headliner machine or microcomputer that also types large print.

As with slide presentations, a key to effective overhead transparencies is organization. Determine your objectives before you develop the transparencies. Keep the information on each transparency to a minimum. One point per transparency is desirable. If you need to make succeeding points from a single transparency, then arrange the transparency so that points can be uncovered and discussed in proper sequence. The use of covers for transparencies is essential. Never uncover points of information before you are ready to discuss them. Few things an instructor can do are more distracting.

High quality overhead transparencies are a valuable teaching aid. Even good quality materials must be used properly to be effective. Do not hesitate to seek help from people with artistic talent to improve their quality.

Set up and presentation tips will be discussed later in this article.

Models

An effective presentation by any instructor will include the following steps:

1. Explain the concept;
2. Demonstrate the necessary skills;
3. Involve the student in an activity;
4. Evaluate the student's work.

One of the most basic methods of explanation and demonstration which teachers often overlook is the use of models. A model-sized tractor or piece of farm equipment on a properly painted and decorated sheet of 4 x 8

plywood can be an acceptable substitute for some field work. Students or teachers can also build and use effective models. You can learn more about building models by checking your local bookstores for references on the design and creation of stage scenery for the theatre. Two good sources are listed in the references at the end of this article.

Units on teaching farm structures lend themselves well to modeling techniques. In fact, total farmstead design can be taught very effectively with models. Models have an additional value of instilling pride in workmanship. When working with models make sure you pick a scale that will be large enough to allow for detailing and yet not so large that the model gets out of hand. In addition, make sure you have a good knowledge of materials, glues, paints, and techniques involved before getting started. Without a good knowledge base the activity will not be as productive and may in fact become detrimental to your goals.

Models can also be effective public relations tools. Failure to display student-built models for a support group is a public relations opportunity you have missed. Encourage students to take the completed models home to share with families. Students will likely keep and value those models for years.

Presentation Tips

The following tips are offered to improve presentations. Many of the tips are valuable, using audio-visuals other than those discussed in this article. These include:

1. Place the screen in a location that allows for maximum visibility from various points in the room. Many charts and graphs are available to give you the technical information on proper screen size and location. The best rule to follow is to have the students view the screen from a straight on angle. The more off-center the screen, the more problems people have seeing. Portable screens should be placed as high as possible and in the darkest portion of the room. To illustrate the importance of this concept, place a slide or transparency on the screen. Next, vary the ambient (room) light from lower to higher levels. You will note that various colors differ in intensity. In addition, small print becomes less distinct.
2. Know the equipment you are using. It is always best to set up while you are alone in the room. A table or similar piece of furniture is a poor item to use for a projector stand. Place the projector in a location that will give the best projection and be in the least line of sight of your audience. A permanent platform above head level and at screen level is one way to avoid problems.
3. Check the operation of your equipment before you attempt to use it. The following suggestions should be considered:
 - a. Turn on the machine and projector lens. Line up on the screen in the appropriate place for as large a size image as you can. Check the edges of your image for focus. When the edges are in focus, the projected image will only require fine tuning.
 - b. Load whatever media you are using. If time permits, run through the equipment to ascertain if your order of presentation is appropriate.
 - c. Be sure to check the audio tape or public address system for proper operation. Change the microphone and

(Continued on Page 8)

Audio-Visual Materials: A Key to Increasing Teacher Effectiveness

(Continued from Page 7)

speaker placement or the volume for optimum operation.

d. Do your housekeeping. Make sure all cords are out of the way. If cords can not be placed out of the way, secure them firmly with duct or gaff tape.

4. Exude enthusiasm for the topic. Use your best speaking voice and follow your lesson plan.

5. Always have spare projector bulbs available in case one burns out. Do not attempt to solve any other malfunction on the spot. It is best to pick up prepared material and continue.

6. Plan for systematic evaluation of your audio-visual materials and techniques. We are in an era when most educational systems demand an ongoing evaluation process. Run an honest self-evaluation with yourself. Document your work in developing audio-visual materials. Invite peers to critique your materials.

Summary

This article has merely touched the surface of the possibilities available in audio-visual teaching materials. Proper use of high quality audio-visual aids is a convenient method by which any instructor can increase effectiveness.

Volumes have been written on the subject of audio-visual aids. Many states require certified teachers to have taken coursework in the development and use of audio-visuals and related equipment.

Many high quality audio-visuals are available commercially. The most effective, however, have been and will continue to be those materials developed by instructors. The most successful vocational agriculture programs are based on and attuned to local needs. Audio-visual materials that are tailor-made for the local program will always be the most effective.

References

- Gillette, A.S. (1972). *STAGE SCENERY: ITS CONSTRUCTION AND RIGGING* (2nd ed.). New York: Harper & Row, Publishers.
- Parker, W.O. & Smith, H.K. (1974). *SCENE DESIGN AND STAGE LIGHTING* (3rd ed.) New York: Holt, Rinehart and Winston Inc.
- Phipps, L.J. (1966). *HANDBOOK ON AGRICULTURAL EDUCATION IN PUBLIC SCHOOLS*. Danville, Illinois: The Interstate Printers & Publishers, Inc.

THEME

A Potpourri of Tips

My single most successful teaching technique is daily quizzes. Nearly every day, I begin my classes with a five or ten point quiz over material covering the instruction of the previous day. This practice encourages students to keep up on class material and to do their assignments regularly. I am also able to find out if students have learned material or if I need to spend more time on a particular topic. Every day, students are aware of how they are doing and are not surprised by their grade at the end of the quarter. The questions used on the quizzes then serve as the basis for unit and quarter tests. Test preparation is made easier and students are familiar with the types of questions that are asked.

Reviewing for tests is made more enjoyable by using index cards containing relevant questions and answers. Cards are labeled with a number one through five according to difficulty. Students are divided into teams which take turns choosing a level of difficulty. They are asked the question. If it is answered correctly, that team receives the indicated number of points. If it is answered incorrectly, they lose the points and the next team in line has an opportunity to answer the question and receive the points. Point totals are maintained on the chalk board. At the conclusion of the review session members of the high point team receive five bonus points. Another way I use the cards is to ask individual students the questions and, if answered correctly, give the cards to the students. At the end of the review session the student who has collected the most cards receives bonus points.

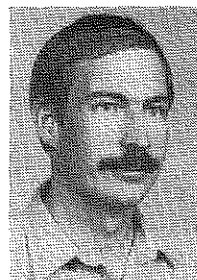

By JEFF ROTERING

(Editor's Note: Mr. Rotering is the Vocational Agriculture Instructor at Hettinger High School, Hettinger, North Dakota 58639.)

Using Magazines

While reading farm magazines I often tear out articles that may be useful in my agricultural classes. As an occasional assignment or as work to be done on days when I must be away from school, articles are distributed to my students. They are required to read the article and prepare a three to five minute report to be presented to the class the next day. This has provided public speaking experience and is an effective way to disseminate the information from collected magazine articles.

Compiling Worksheets

Three years ago I decided to collect all the worksheets and handouts used in my welding class and assemble them to form a workbook. Since then I have compiled similar workbooks for most of the units that I teach. The workbooks are distributed during the first class session of each unit. My students then know exactly how much

material will be covered before moving to another unit or beginning the laboratory portion of the unit.

Planning is simplified and these workbooks are easily used by substitute teachers. I am able to appear more organized than if I am distributing paper every day. The students tend to keep their materials in better physical condition and are less likely to lose them.

Safety Reports

Safety reports are used to promote an attitude of safety in the laboratories. Whenever a safety violation is observed, students are required to complete a safety report before being allowed to return to the laboratory. The safety report consists of five questions relating to the particular safety violation and its possible effect on the offender or other workers. Each question requires an answer of at least 25 words. Counting the words in each answer is simplified by the 25 blanks which follow each question. Answers are written one word per line.

Using Computers

Computerization of my grades has allowed me to easily distribute a progress report to each student several times during each grading period. Students can easily anticipate

the grade they receive at the end of the grading period if they have an idea of how they are doing throughout the grading period.

The FFA chapter recently purchased twelve desk-size solar powered calculators. The calculators are used only in the agriculture room. The large size of the calculators prevents their loss or theft.

Using Bulletin Boards

At the beginning of every year, one bulletin board is used for a calendar covering the entire school year. School and FFA events are placed on the calendar, as are test dates and due dates for class projects and long range assignments. This practice simplifies scheduling, and individual students are better able to plan their own activities.

A list of all agricultural students, arranged by class, is typed and copied at the beginning of each semester. These lists are used almost daily. They are convenient for keeping track of money collected from fund raising projects, for substitute teachers, and as lists of participants in field trips or other activities.

These teaching ideas have made my job more enjoyable and have made me a more effective and efficient teacher.

THEME

Storage: Today's Project

What does \$50.00 buy today? (Hint: something everyone can use!) Answer: "Storage", but don't tell anyone yet!

Every year, about the second week of school, students start asking their vocational agriculture instructor, "What can we build that does not cost too much, that anyone can use, and is strong and flexible?" Any student with basic shop skills can build this project for home and farm shop use, or it can even be sold to a neighbor. Every vocational agriculture laboratory has the tools needed for the construction, and it will not take up too much space, either. As we strive to teach students basic skills, we must never lose sight of the vocational objective. Students must be able to apply those skills to the job situation.

The steps in construction of this project require the student to learn and apply all of the following skills: squaring, measuring, nailing, sawing, and a good eye for craftsmanship.

When we start any project, selection of materials is of utmost importance. In this type of cabinet, use #2 white pine. Be sure to check that the lumber is not warped or cupped. Consult the bill of material for a full list of materials needed.

When cutting materials, this is a good time to teach students that actual length of the shelves may be different than the overall project length depending on the type of butt joint used in the assembly. This is the case with the



By MARLIN SEEMAN

(Editor's Note: Mr. Seeman is the Vocational Agriculture Instructor in Hampton Public Schools, Box 37, Hampton, Nebraska 68843.)

shelves that are to be cut 1/2" shorter than the outside dimension of 64 inches. The dividers are to be cut to 11 1/2". The 4' x 8' plywood sheet is cut in two pieces, one 64" by 48" for the back, and the other 32" by 48" for the door. The assembly of this project with its many aligning parts requires great care in squaring.

For the dividers to be properly aligned, have the students square a line down each side of the shelf to assist them in alignment of the dividers. It is also helpful to pre-drill nail holes in the shelves. The nail hole should be spaced at 1 1/2" intervals across the board. The shelves and divider may be preassembled as a unit. Be sure all the dividers are spaced at 10 inches and are very square. Flexibility may be added to this project by changing the number of dividers.

(Continued on Page 10)

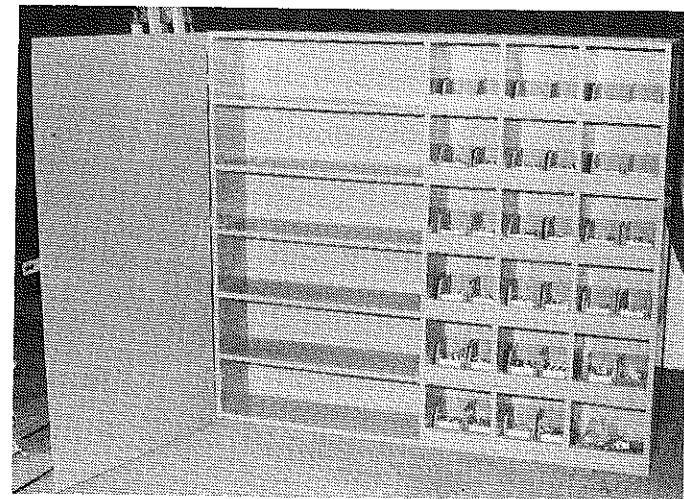
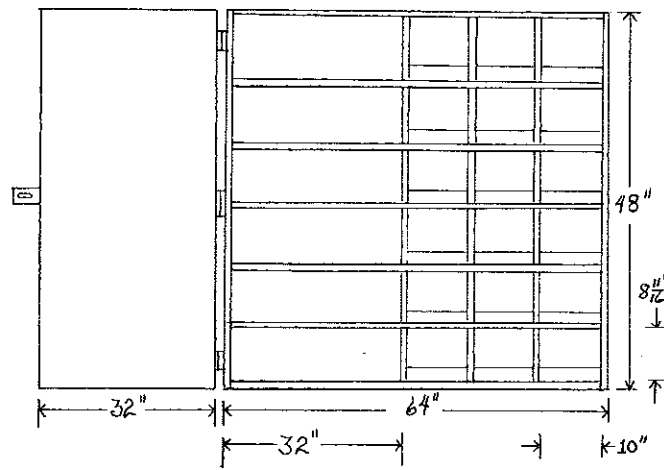

Storage: Today's Project

(Continued from Page 9)

Now stack the shelf units and toe nail together, adding one shelf unit at a time, starting at the bottom. Nail on the sides and cover the back with the plywood. The fronts of the pigeon holes can be blocked with a 1 1/2" by 10" board. The final step of assembly is to install the door, by using three-inch butt hinges, fastened by 5/32" by 1 1/4" bolts. The door may be reinforced by adding a 1" x 6" board along the outer edge of the door. Painting will add life and beauty to this project.

A student should complete this project in 10-12 hours of laboratory time.

Bill of Materials:

- 1 - 1/4" A.C. Plywood 48" x 64", back panel
- 1 - 1/4" A.C. Plywood 48" x 32", door panel

- 2 - 1/10 #2 WP 48", sides
 - 7 - 1/10 #2 WP 62 1/2", shelves
 - 18 - 1/10 #2 WP 8 11/16", dividers
 - 3 - 3" butt hinges
 - 18 - 1 1/2"/10" #2 WP, front blocks
- Lumber can be combined into:
- 1 - 4/8 - 1/4" plywood A.C.
 - 2 - 1/10 - #2 WP 10' ends
 - 1 - 1/10 - #2 WP 8' dividers
 - 1 - 1/10 - #2 WP 16' shelves and fronts
 - 1/2 pound #8 d finish nails
 - 1/4 pound #8 d box nails
 - 18 - 5/32" x 1 1/4" flat head bolts
 - 1 hasp
 - 1 quart paint

THEME

Six Tips for Using Problem Solving

When the term "problem solving" is mentioned to teachers, many things flash through their minds as they recall experiences with using problem solving. For some, it refers to enjoyable teaching situations in which true learning occurred and the students were able to accomplish the class objectives. For other teachers, problem solving has vividly imprinted upon their minds situations where the class got out of hand with the end result being that teachers felt the class was a total waste. Perhaps for others, the term problem solving brings no conceptual thought as to what is the correct approach to follow when using it in the teaching/learning process. I believe each of us, as we have developed professionally, can recall all three instances occurring in our teaching.

Only through a working understanding of the problem solving process can we effectively use this teaching approach in our classrooms and laboratories. I like to think of problem solving and vocational agriculture as going



By JOHN R. CRUNKILTON

(Editor's Note: Dr. Crunkilton is Professor and Program Area Leader of Agricultural Education at Virginia Polytechnic Institute and State University, Blacksburg, Virginia 24061.)

hand in hand. It is just like thinking about ham and red-eye gravy, or a car and air conditioning, or John Deere and green. Each of these situations would not be whole without the other part. This article will identify tips that will help individuals better understand problem solving and encourage teachers to perfect it to a higher degree as part of their teaching skills.

Teacher Must Believe

No matter what else might be said about the problem solving process, if the teacher does not philosophically believe in the problem solving approach to teaching, then it will not work. What I write or what other writers have said will make no difference. A teacher must believe that problem solving is a sound approach to use in teaching.

Keep in mind that one of the responsibilities of the teacher is to help develop the student's ability to think. We can say with a certain degree of assurance that no teaching technique, approach, or method will transfer to students the ability to think and to solve problems with 100 percent effectiveness. But we do know that problem solving may come closer than anything else in our approaches to learning that will help students to think and to apply what they have learned. But before students can reach this learning stage, the teacher must believe in the problem solving process.

Plan Your Lessons

Perhaps we can equate planning with an old saying that goes: "no one plans to fail, they just fail to plan." To follow the problem solving approach in teaching, teachers must plan the lesson for the entire class period. Planning means that teachers select the particular approach to take with a topic, decide how to motivate the students, and how to sequence the material so it will enhance learning for the students.

We can relate this activity to developing the lesson plan, an outline that is complete with all information teachers need to teach effective classes. If a teacher does not plan for a lesson using the problem solving approach or for that matter, any other teaching approach, you can be assured that whatever is the result of the teaching, it will be less effective than what it should have been. So always approach your class with a plan in mind.

Steps are Important

Teachers need to follow the correct steps for problem solving to work effectively. Keep in mind that an approach to use in problem solving would be that immediately after a teacher motivates his/her students on a topic, ask the students, "why is it important for you to be knowledgeable about the topic you are discussing?" The students will come up with some reasons why they should be knowledgeable about that particular topic.

After a short discussion, then the teacher asks, "what must you know in order to do those things which you said were important?" The key here would be for the teacher to list the students' responses on the board in question form and, at this point, the teacher adds any questions (problems) overlooked by the students. These questions then become problems to be solved throughout the remaining part of the period and for the remainder of the unit. These problems can now serve as a basis for conducting class.

It is during the solving of these problems that the teacher can use different teaching techniques, instructional aids, and bring into the class situations relating to the community or the students' backgrounds. These learning activities should eventually lend themselves to the application stage at the end of the class. We must remember that problem

solving not only involves getting a class started on a particular topic, it also refers to the teacher's responsibility to help students answer additional questions or problems that arise as they learn more about the topic at hand.

Information to the Taught

Problem solving cannot be effective unless teachers have done their homework and are familiar with the technical content to be taught. This includes the objectives for the class, the problems that will be solved with the students' help, and the specific content for each problem that the students must learn.

It must be remembered that a successful problem solving process is very much dependent upon the problems that are identified for the class to solve. These problems must originate from the learning objectives for the class so that as a teacher guides the learning process to solve these problems, the appropriate content will be taught leading to a much greater chance that the learning objectives will be achieved.

Students Must Be Involved

Students must be taught about the problem solving process. Teacher must acquaint students with the reasoning why the problem solving process is being used, the procedure that will be used in teaching by using the problem solving process, and the responsibility the students have in the teaching/learning process.

Those who guide the learning process must always remember that effective teaching is not a one-way process, from the teacher to the student. It is a two-way interaction and students should participate in the learning process if it is to be an effective teaching/learning situation. The more you involve the students, the more effective a class will be because at the heart of the problem solving process is student involvement.

Practice Helps to Perfect

The principle of learning (that of the Principle of Practice) taught to our undergraduates in methods' courses has always placed the emphasis on the students. In other words, students will learn better if they are given the opportunity to practice what has just been taught or while it is being taught.

But the "P" for this practice refers to the teacher. There is only one way that a person can learn to use the problem solving approach and that is to practice it. I will guarantee that the first time teachers use it, they will not be satisfied. In fact, they may even want to give up and say it will not work. Problem solving is something that educators continue to perfect over their life time and in many situations they always feel like they could have done a better job. But, the first step is to practice it, use it, think about it, then practice it again.

In summary, two points I would leave with the reader for using problem solving deal with what I have eluded to during this article. One, the success or failure of using problem solving can often be traced directly to the effectiveness of planning. And two, you must practice problem solving to perfect this teaching approach.

Ideas From Florida

Urban students are frequently a challenge when it comes to providing meaningful supervised occupational experience programs. These students frequently have limited opportunity, especially for ownership programs. An innovative strategy for meeting these students needs is ownership at the school.

Ownership programs at school generally fall into one of two categories. The first type is when the student totally owns and operates the enterprise using the school only as the physical location for the project. For example, a student might utilize the land laboratory to house a steer or a small swine operation. The student provides all of the inputs including management and marketing. This concept also works well at schools where there is greenhouse space or land for crops.

Cooperative ownership is another method of ownership at school. Students can own the enterprise either in cooperation with other students or with the school. When conducted with other students, each student is responsible for a share of the cost of production and shares in all labor associated with the enterprise. The school provides the space for the enterprise and all labor occurs after school. The income is divided among the students.

Cooperative ownership with the school allows the student to share a portion of the risks with the school. The student puts up a portion of the production costs out front. All labor is provided by the student utilizing equipment and space provided by the school. Income from the enterprise is divided at a predetermined percentage.

As more and more urban students enroll in vocational agriculture programs, creative approaches to providing supervised occupational experience must be utilized. Ownership at school is just one of many non-traditional approaches that is working.

Computer Assisted Job Searches

Assisting with the placement of vocational agriculture program graduates is an important role of the vocational agriculture teacher. As more and more pressure is placed on programs to be accountable for placing students in agriculture related occupations, job placement will be even more important. To assist students in searching for a job, the Agribusiness Advisory Committee of the Broward County School System in Florida has come up with an innovative approach for communicating job openings: a computer based job bank.

One phone call from an employer contacts everyone of the nineteen high school vocational agriculture programs in the area. Within hours, every student can know about the position.

The system works through a network of micro-computers in the schools connected through phone modems. Job openings are called in to one central location where they are entered into the system. Each employer is

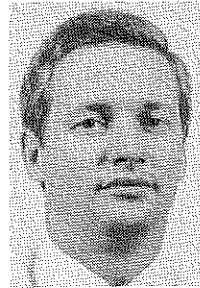

BY LARRY R. ARRINGTON

(Editor's Note: Dr. Arrington is in the Department of Agricultural and Extension Education at the University of Florida, Gainesville, Florida 32611.)

requested to provide the following information:

1. Category [i.e., Nursery, Landscape, Irrigation, Municipality, Cemetery, Golf Course, Agricultural Mechanics, Small Engine, Livestock, Pest Control, Co-op (on job training)].
2. Name, address, phone number, contact person
3. Job description
4. Rate-of-pay
5. Hours
6. Any miscellaneous information you may wish to add; such as, benefits or insurance.

Students seeking employment can then call up employment opportunities in their vocational agriculture classroom. A sample printout appears below.

REC#: 7

1. Date: 11-20-84
2. Name: Palm Aire Golf Course
3. Add: 2501 Palm Aire Drive
4. City: Pompano Beach
5. Phone #: 975-6215
6. Contact Person: Tom Stone
7. Job Description: Turf Worker
8. Rate of Pay: \$4.00 per hr.
9. Hours: 6 a.m. - 3
10. Experience:
11. Status: Open
12. Misc.: Benefits

The Cover

The selection and use of appropriate teaching tips should aid the teacher of vocational agriculture in improving instruction and in more efficient use of time and energy. Teaching tips are useful in the areas of teaching strategies, audio-visual aids, laboratory projects, public relations, community service, and other facets of a program of vocational agriculture. Design of the cover is by Diana Morawetz, Secretary, The Ohio State University, Department of Agricultural Education.

Ohio Emeriti Share Tips

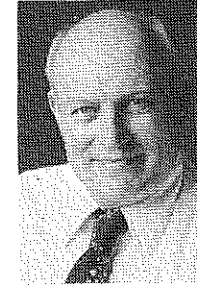

BY ODELL C. MILLER

(Editor's Note: Mr. Miller is an Emeritus of The Department of Agricultural Education at The Ohio State University.)

Visual Aid for Genetics

When I taught genetics, I used the colored plastic fasteners from bread packages and an 18-inch piece of doweling. One end of the dowel was painted red (6") and the other end (6") was painted white. The middle six inches was left plain. The red end would represent the male, the white end the female, and the plain section, the offspring. The colored fasteners would hook over the doweling so that the different colors could represent or illustrate genes, recessive characteristics and dominant characteristics just by moving the fasteners around from male and female to offspring.



BY GILBERT S. GUILER

(Editor's Note: Dr. Guiler is an Emeritus of The Department of Agricultural Education at The Ohio State University.)

Greet Your Students

A specific observation I made during many years of classroom supervision was that of student attitudes. This was particularly noticeable as they came into the classroom with reluctance and little enthusiasm only to find the teacher shuffling papers and trying to organize what appeared to be a last-minute preparation for a way to spend the period with the students. Obviously, the students' lack of enthusiasm and the teacher's "too busy" attitude did not present the atmosphere for a learning situation or an interesting lesson.

Teachers, let us change the scene and enhance the beginning of a new learning experience. Be prepared before the bell rings and greet each student with a handshake, a smile and a pleasant greeting as they enter the classroom. Such a greeting will present a refreshed atmosphere and positive setting for the day's lesson. If the teacher appears with such a positive and happy attitude when the students arrive, they, too, will react with a more acceptable feeling for listening and participation in the learning situation.

This bit of warmth displayed on the part of the teacher seems to convey to the student that something worthwhile awaits them and that they are welcomed. Such a personal interest shown by the teacher lets the students know that someone is interested in their personal problems and educational growth. It helps to erase some of the many frustrations and negative attitudes such as "I can't - I won't - I don't care - I don't know how or I couldn't care less about the class or vocational agriculture activities."

Give your students that warm, positive feeling when they enter the classroom by assuring them of their importance and that they truly are welcomed to a real learning situation. You will be rewarded many times in return by their attitude and feeling toward the total vocational agriculture program.



BY LEON W. BOUCHER

(Editor's Note: Dr. Boucher is an Emeritus of The Department of Agricultural Education at The Ohio State University.)

Teaching For Understanding

I found it helpful to have a board 1' x 6" x 12" with the word, "WHY?" on it hanging in front of the classroom.

Teaching for understanding is necessary if students are to change their behavior in a positive manner. I observed many students and beginning teachers hurrying through lesson plans by accepting answers from students without an explanation as to why the answer offered was correct. When this situation occurs, the teacher should direct the students' attention to the sign in front of the room and wait for an explanation.

A revolution in teaching could occur if all instructors would strive for quality thinking rather than just the production of correct answers as a measure of student growth.



BY RALPH E. BENDER

(Editor's Note: Dr. Bender is an Emeritus of The Department of Agricultural Education at The Ohio State University.)

Principles of Learning

From my 45 years of teaching and study of the teaching-learning process, I believe:

(Continued on Page 14)

Techniques For Motivating Students in SOEPs

(Continued from Page 15)

22. Picture students and projects in slides used at an FFA banquet, open house, etc.
23. Use the "Four Stars" movies.
24. Use speakers — former students, former award winners, state FFA officers; professionals.
25. Project a positive teacher attitude.
26. Demonstrate teacher know-how.
27. Provide print materials describing the program.
28. Provide SOEP pamphlets for 8th graders/prospective students.
29. Conduct record book contests.
30. Sponsor animal rings.
31. Utilize a school farm — animals, crops, nursery; greenhouse.
32. Implement buddy system — have experienced students provide guidance for the inexperienced.
33. Emphasize career establishment.
34. Arrange for work-study credit for students conducting SOEPs.
35. Teachers share SOEP teaching ideas through professional organization activities.

Most will agree that good classroom instruction on what is supervised occupational experience and how to personally conduct an SOEP is the heart of effective motivation. Organizing instruction to achieve these two objectives has been a troublesome problem for many teachers. In recent years, several states have developed teaching materials to help.

Maryland System

Vocational agriculture teachers, teacher educators, and state staff in Maryland have developed an extensive competency-based curriculum for SOEPs. While all competency sheets with related materials are not complete, a listing of the competencies identified may be helpful to teachers and curriculum writers. The competency profile as now developed is as follows:

1. Define and understand SOEP.
2. Identify personal interests in horticulture.
3. Select an SOEP.
4. Select a training station for placement in SOEP.
5. Set goals for placement in SOEP.
6. Plot the home farm or business.
7. Plan improvement projects for the SOEP.
8. Plan supplementary skills for the SOEP.
9. Plan production projects for the SOEP.
10. Maintain a daily diary for the SOEP.
11. Record expenses using the double entry system (Maryland Record System).
12. Record receipts using the double entry system (Maryland Record System).
13. Figure depreciation.
14. Make inventories.
15. Develop a financial summary and a networth statement.
16. Prepare a crops enterprise analysis.
17. Prepare a poultry enterprise analysis.
18. Prepare a livestock enterprise analysis.
19. Prepare a dairy enterprise analysis.
20. Prepare improvement project records and summary.
21. Prepare a supplementary practices record.
22. Evaluate an SOEP (Self/Employer/Teacher).

Examination of the above competency profile makes it evident that a substantial amount of classroom instruction is needed for students to develop these competencies. It is the writer's belief that most teachers who experience difficulty in motivating students regarding SOEPs experience the difficulty because of inadequate classroom instruction on the whys and hows of SOEPs.

Systematic instruction in the above twenty-two competencies, appropriately spread over a year or two and implementation of some of the more promising ideas presented, may solve some of your problems of student motivation for effective supervised occupation experience programs in vocational agriculture.

cur and each morning before classes begin, fill out a number of late passes with all the necessary information, except the student name. Then when time becomes a problem and students may be late for their next class, all you have to do is fill in the names.

—Kerry S. O'Dell

Students Harassing Other Students:

Some students constantly harass other students as they proceed to and from class. This harassment may be physical, i.e., poking or pushing. Standing in the doorway or hall between classes when possible is effective if harassment is anticipated.

—Kerry S. O'Dell

THEME

Improving Visual Communication

BY CLIFF McCLAIN AND JACK PRINCE

(Editor's Note: Mr. McClain is with the Agricultural Education Department at the University of Nebraska, Lincoln, Nebraska 68583-0709; and Mr. Prince is the Coordinator for Instructional Resources for the Wyoming Department of Education, Cheyenne, Wyoming 82002.)

Selecting What to Project

Each of us has endured meetings where presenters have projected typewritten (or worse yet, poorly handwritten) visuals and then insulted our intelligence by reading aloud the information to us. If you have something you want your students to read, make and distribute copies of it!

Reinforce Screen Material

Projecting a few, large, choice words and/or images onto the screen and reinforcing them with your own verbal explanation or enhancements, off-screen, tends to strengthen your message. The large, key words or images give the class something upon which to focus, while you are speaking. But it does not give them too much information to assimilate, and they can listen to what you have to say about those key ideas.

Use Symbols Where Possible

The best presentation occurs when you blend visual symbols with verbal symbols. Illustrations are less abstract than are words alone and they can simplify an otherwise wordy explanation. Simple illustrations can also break the monotony, add humor (or other desired feelings), garnish interest, and generally make a presentation more easily understood. Hopefully, it will also be more fun. After all, a picture can be worth a thousand words.

The idea is to make a verbal message visual. The problem is that most of us think we do not have the artistic ability, the production capabilities, nor the time to create anything but the simplest of visual messages. But, therein, lies the magic of visuals. The simpler they are, the better they are. Through the use of large, key words or illustrations, reinforced by an oral explanation or enhancement of their meanings your classroom presentations can become more easily understood, more exciting, more interesting, and, overall, more effective.

When is the last time you used the overhead projector as a part of your planned classroom presentation? Many of you might say, "I use it every day for every lesson I teach", while others will admit that "it might be somewhere in the storage room under a couple of inches of dust, but I wouldn't use it even if I could find it".

These are two extreme examples between which most of us fit. Now that we have determined that your usage of visuals is probably somewhere in the middle (while also using a combination of chalkboard, handouts, study guides, bulletin boards, etc.) the question then becomes, how good is the quality of your visuals?

With some thought and practice, each of us can develop excellent presentations using the overhead projector as part of our lessons. Such practice can make each visual more readable, more interesting, and more meaningful to our students. Good visuals can also help organize lessons in a manner which keeps the presentation flowing. Also, once developed, a set of visuals can be filed and re-used, sometimes for several years with only minimal modifications. In order to develop better visuals, there are five basic rules to follow.

Keep Visuals Simple

Many so-called visuals are too wordy! A projected page from a curriculum guide or textbook does not make a good visual. Instead of projecting a visual message, you've just increased the physical size of a verbal message. With visuals, the use of too many words may complicate the message, since the words may be written so small they can often neither be seen nor read. Visuals can easily be improved by reducing the number of words used, increasing the lettering size, and adequately spacing the words.

Select Key Words That Trigger Interest

The best visuals are comprised of simple, key words or images which pinpoint major ideas and, at the same time, stimulate interest; thus, preparing students for what you are about to say. Photographers and printers will tell you that when they want to sharpen an image, they reduce it rather than enlarge it. A few choice words can have this same dynamic effect. By using a few choice words on a visual you can focus student attention. Think about some of the billboard advertising signs you have seen.

Upcoming Themes:

January Vocational Agriculture and the Excellence Movement
February Staying Current: Agricultural Mechanics

March Staying Current: Agribusiness and Farm Management
April Staying Current: Crop and Food Production

An Engine Valve Display

The display is used in the classroom or laboratory to identify valves and valve parts. It can be used during instruction and evaluations. Students can see and touch the valves and parts. Each part is color coded for recognition and identification. The display has helped teach about large and small gasoline engines.

The display was constructed from materials commonly found in most agricultural laboratories. The only items purchased were the paints to color code the parts. The size and sturdiness of the display makes a durable and useful item. It took approximately three hours to finish the display.

Items needed to construct valve display are: 1-6013 or 6011 arc welding rod and welder, 1-exhaust and arc intake valve (large engine), 1-valve spring with valve keepers and valve spring retainers, 1-3" x 8" piece of 1/8" metal, and 1-cut off 10 penny nail, a 5/32" drill bit, and a drill press.

Procedure:

- Drill hole in one of the valve stems. Distance depends on how much the spring is to be compressed. I used a 5/32" drill bit for a 10d common nail.
- Weld one valve upright and one valve upside down on the 3" x 8" piece of metal.
- Paint each part a separate color. I found it easier to scrape the paint off the valve margin and code it unpainted on the color key.
- Assemble spring, keepers, and retainers on the upside down valve.
- Using a spring compressor, compress spring and retainers and insert nail into predrilled hole. Release the compressor and cut off the nail.

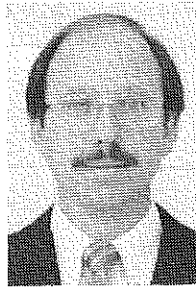

BY RICHARD S. SCHERTZ
(Editor's Note: Mr. Schertz is a Vocational Agriculture Instructor at Moweaqua Community High School, Moweaqua, Illinois 62550.)

f. Make your corresponding color key. Fasten it on the metal so it can be removed should you decide to use the display in your evaluations.

g. Inform the students that the nail is not part of the valve system.

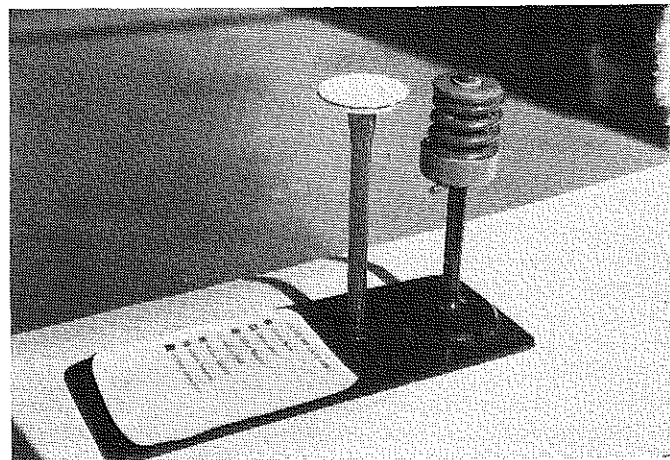

TEACHING TIPS

Assigning Dogs for Grooming:

If students are permitted to select their own dog for grooming, many times they will select a puppy that doesn't need grooming. It is best to assign a dog in need of grooming to a particular student.

— Colleen Garrett

Checking Family Names Before a Visit:

It is embarrassing for all concerned when a teacher visits a student at his/her home and addresses the parents with the last name of the student only to find that the names aren't the same. Prior to making a home visit, the teacher is wise to check the correct last names of all family members, even siblings. Divorces have created the situa-

tion of student names not matching the name of the parents.

— Tom Oglesby

Students Who Forget Notebook In Locker:

Invariably, at the beginning of class, a student will state, I forgot my notebook. It's in my hall locker. Sometimes this is done accidentally; sometimes on purpose (so that a trip can be made down the hall to greet a friend, or in hopes that the student won't have to take notes today). In anticipation of this, a teacher will have plenty of extra paper available for the student to use.

— Jerry Schwochow

Computer Print-Out For Stencils

One laboratory project my students performed this year was routing a sign for the Soil Conservation Service. In the past, they had problems stenciling words on boards to be routed. This idea makes stenciling easy.

A student is to rout a sign that says "Soil Test." He or she begins the project by sitting at the front of a computer. (We use the Apple IIe). The student inserts the disc, "Teacher Utilities, Volume I, Version 3.6," into the drive. The disc, manufactured by Minnesota Educational Computing Consortium, contains a "Block Letters" program. The program allows one to type a message down the page of the printer.

After selecting the Block Letters program, the student selects one of five letter sizes. The sizes are numbered and correspond as follows:

- Size 1 = 1 1/4 inches high by 3/4 inch wide
- Size 2 = 2 3/4" x 1 1/4"
- Size 3 = 4" x 2 1/2"
- Size 4 = 5 1/2" x 3 1/4"
- Size 5 = 7" x 4"

The student then types the letter size in front of each letter to be printed. For the number 2 size words, "Soil Test," one would type 2s 2o 2i 2l 2t 2e 2s 2t. The words will be printed in 2 3/4" x 1 1/4" block letters.

This letter size fits and centers on 1" x 4" pine. After removing the paper from the printer, the next step is to use wood or white glue to paste the paper to the surface of the wood to be routed. Care should be taken to be sure that every square inch of the wood surface contains a light coat of glue. Press the paper into place.

After the glue is dry, select a router and bit that provides the desired lettering groove. Trail the router and bit over the computer printout. Be sure to groove the wood approximately 1/8" deeper than normal to allow for removal of glue and paper from the project.

After the sign has been routed, the paper and glue may be removed by using a planer. One may wish to paint or



BY DAVID L. MOORING
(Editor's Note: Mr. Mooring is the Vocational Agriculture Instructor at North Lenoir High School, Lenoir, North Carolina 28551.)

stain the letters before planing. The glue and paper will not allow stray brush strokes to permeate and stain the face of the board where another color is to be used.

The last step is to complete the project with finish sanding and staining. The product is a neat, even lettered, and well-finished sign. Students may be motivated by the use of a computer. The amount of time you spend is less because your stenciling process consists of typing your sign and gluing it in place. There are no letters to cut out, to outline or to arrange. Just type, print, glue, rout, finish and color.



TEACHING TIPS

Making Chalk and Erasers Student-Proof:

Students find it very difficult to leave chalk and erasers in the chalk tray. They find great pleasure in throwing them around at every opportunity. Anticipate that this might be a problem and remove all chalk from the chalk tray. Keep one piece in your pocket and the remaining pieces in the desk. Keep all the erasers except one, also in your desk. This also reduces the chances of getting chalk stuck inside your eraser without you knowing about it,

thus eliminating the possibility of writing and erasing in one stroke.

— Kerry S. O'Dell

Identifying the Proper Pet:

When working with pets in an animal care program, anticipate that students may get the pets mixed up. To prepare for this possibility, be sure to log the pet breed, kennel number as well as the animal markings when the pet is brought to the school.

— Colleen Garrett

Wheel Alignment For A Tractor Axle

Most instructors of vocational agriculture find themselves confronted with the student question, "What should I use for an axle for my project?" The answer may and probably will vary in almost every instance. There is one problem which remains the same — axles are seldom the exact size needed for the student project. Modification or even complete construction of the axle may be required.

This easy-to-build and use wheel alignment jig can reduce mistakes and insure a quality product. Advantages of this wheel alignment are as follows:

- Inexpensive to construct.
- Little time involved with design or construction.
- Can be used for different types of axles: straight, dual-wheeled or drop.
- Students can build axles in a short period of time.
- Can build axles of any length.

Bill of Materials:

- 1 @ 9' x 4" x 3/8" Angle Iron
- 4 @ 3" x 4" x 3/8" Angle

Procedure

Place the 9' section of angle iron with the sides up; place the 3" pieces with the sides down at each end (as shown in Figure "A") to form an "M" as viewed from the end, place the four 3" pieces of angle iron on both ends to keep the 9' piece in a V position. They will act as supports for the weight of the axles. The main items required to build the axle will be the two spindles and pipe or trailer house axles cut to the required length.

To use this alignment jig, (1) remove the tires from the rims, and (2) place the rims on the axle so the wheels rest at the four points on the jig as shown in Figures B and C.

This wheel alignment jig will be a practical tool for the vocational agriculture department. With this inexpensive, non-complicated, handy item, vocational agriculture instructors have an effective way to solve one problem in their shop.

BY JIM COONEY

(Editor's Note: Mr. Cooney is the Vocational Agriculture Instructor at Elko County High School, Elko, Nevada 89801.)

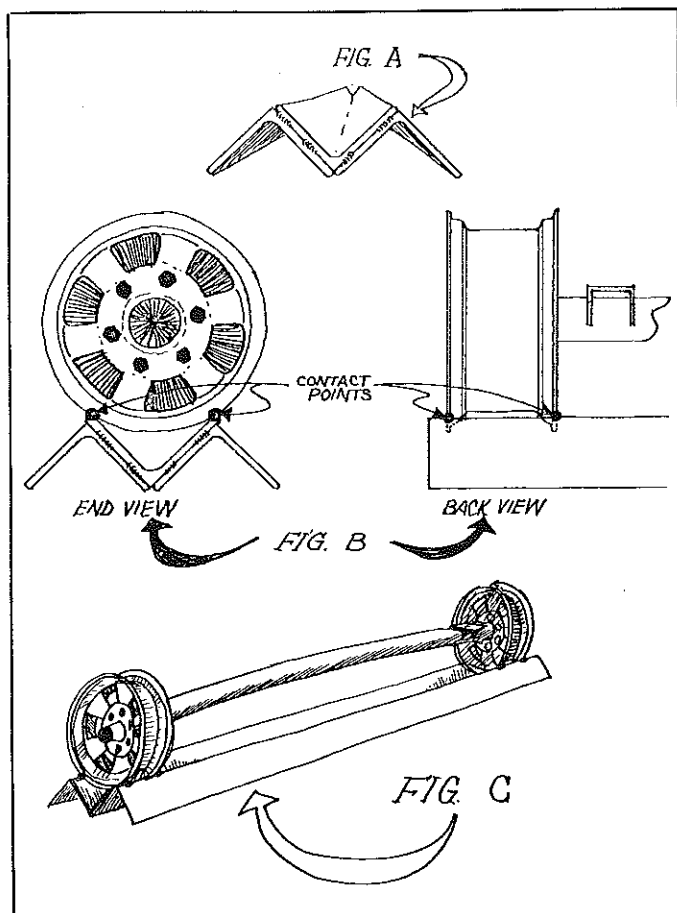

TEACHING TIPS

Preparing for Class:

A vocational agriculture teacher has a very busy schedule which sometimes results in the teacher not being adequately prepared to teach a certain class. Consequently, the teacher tries to "snow" the students. As a result, students quickly recognize the unpreparedness and lose interest in the subject and confidence in the teacher. If the teacher's background in a particular technical area is weak, and a student has some expertise in that area, use the student to help teach the lesson. Be prepared for this situation by learning the backgrounds of the students.

—Tom Oglesby

Receipts For Paid Fees:

If you do not give students receipts when they give you money for fees, supplies, etc., anticipate that some student at some time will try to claim that he/she paid you, when in fact he/she had not. If the student convinces you that you were in error and not the student, other students will try to pull the same stunt very soon. Always use receipts!

— Marvin Hemminger

Classroom Check List



BY CYNTHIA M.A. HIGGINS

(Editor's Note: Ms. Higgins is a Vocational Agriculture Instructor at Morgantown High School, Morgantown, West Virginia 26506.)

One of the things I do to get students more involved in the program is to make a check list out of a large piece of poster board. On this sheet are the names of the students and all the class assignments and FFA activities we are doing or have completed. Each time students successfully completes an activity they get a star in that column. All assignments are recorded on the sheet, including tests taken, homework assignments given, quizzes, etc. FFA activities are also entered on the check list. This year we participated in a great many activities including the homecoming parade, the district tractor driving contest and the sub-district scholastic contests, and held many fund raisers. Students who participated in these activities receive a star in the column by their name and under the corresponding activity.

At the beginning of the year, the seniors were concerned that this system was juvenile. As the year progressed, I noticed that all students were adding up their "stars" and comparing their numbers with others, including seniors.

Aside from getting the students more involved, the chart is also an excellent way of letting them know where they stand at all times. If they cannot remember what they have completed, all they have to do is look at the check list. When parents come in to discuss their child's progress, they are invited to look on the chart and see exactly where their child stands at that time.

I no longer have to remind students of work that they have not yet submitted. With the chart, they understand that it is their responsibility to check what they need to complete.

Competition among the students is generally good-natured. I feel that it encourages those students who would

not otherwise participate in certain activities to become more involved.

This check list is an excellent tool for the first- and second-year student using the stars. If upperclass members are not enthusiastic about receiving stars, other kinds of symbols can be used. For instance, a check could be made in the box for work completed. One must be careful, though, if using student grades to insure that student privacy is always maintained.

When picking Star Greenhand this year, the check list became very handy. Instead of trying to remember what each student participated in, all one had to do was to look at the check list.

Check lists of a similar type are often used in the agricultural mechanics laboratory. They also have a place in the classroom setting when recording FFA participation and classroom assignments. The check list teaches the student responsibility and increases FFA participation by adding an element of healthy competition among the members.

TEACHING TIPS

Knowing School Regulations:

Experienced teachers know that when a teacher is unfamiliar with school regulations and policies, students are quick to sense this. As a result, they will take advantage of the teacher. To avoid this situation, learn the school regulations and policies. This knowledge gives a teacher a better sense of control and order.

— Tom Oglesby

Student Under the Influence of Drugs:

When confronting a student who is obviously high on drugs or alcohol, anticipate that to touch them or threaten them verbally may easily trigger a violent reaction and a "no-win" situation for the teacher. Prepare for this situation by deciding to remain calm and to let the proper school authorities handle the situation.

— Marvin Hemminger

Students Who Forget Lab Clothes:

Sometimes students will say that they forgot to bring their lab clothes, and therefore can't work in lab today. Anticipating this situation, a wise teacher will have lab work available for that student to do that can be done in regular school clothes.

— Jerry Schwochow

Making Summer SOEP Visits:

If you have scheduled a visit to a student's home in the summer, anticipate that the student may forget about it, since you were unable to remind the student during school. Prepare for the possible forgetting by phoning the student's home a day or two prior to the scheduled visit.

— Marvin Hemminger

Spur Key Ring

I use this as a teaching aid to create an incentive to use the oxyacetylene torch. There is also several hours of filing and polishing that we do not have in some of our larger projects. The students learn patience as well as precision. The cost is small, if they have to start over they have not wasted a dollar's worth of material.

Construction

The heel band is made from a 3" piece of 1/2" by 1/8" flat strap metal. The corners should be rounded by grinding. Bend the strap over a piece of 1" pipe until it is in the shape of a "U".

The shank is made from one side of a piece of 4" channel iron. Cut the side from the channel iron with a torch, now place in the cut-off saw with the thin side up. Cut about halfway down and 1/8" from the edge, this will create a slot 3/16" wide for the rowel. Move over another 1/8" and cut completely, now the shank is made. It can be made shorter, bent or whatever students want for their own original style. Weld the shank to the heel bank with an oxy-acetylene torch.

The rowel is made from shaft or flat metal 1/8" thick. Drill a 3/32 hole in the center and file points. The same size hole should be drilled in the end of the shank. The rowel



By LARRY NICKESON

(Editor's Note: Mr. Nickeson is a Vocational Agriculture Instructor at Fargo High School, Fargo, Oklahoma 73840.)

pin can be made from 3/32 welding rod. Place the rowel in the shank, put the rowel pin in place and weld with torch on each side.

The key ring is made by putting a stove bolt through each end of the heel band and welding a nut to one side. Finish the spur by filing and using emory cloth. When all the scratches are removed, heat the whole spur with a torch until it turns blue, then cool in oil.

The spur key ring gives a student pride and confidence to take some scrap metal and turn it into something useable as well as profitable. Many other projects have come from this: belt buckles, regular spurs, ash trays, etc.

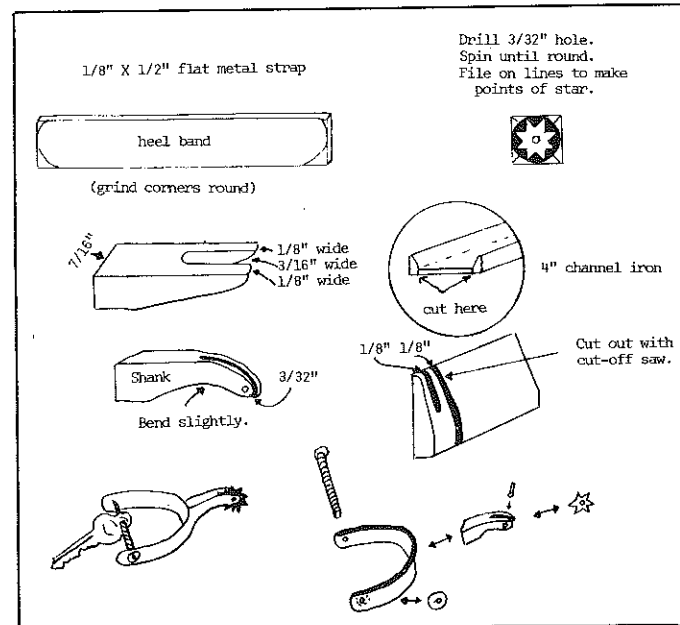
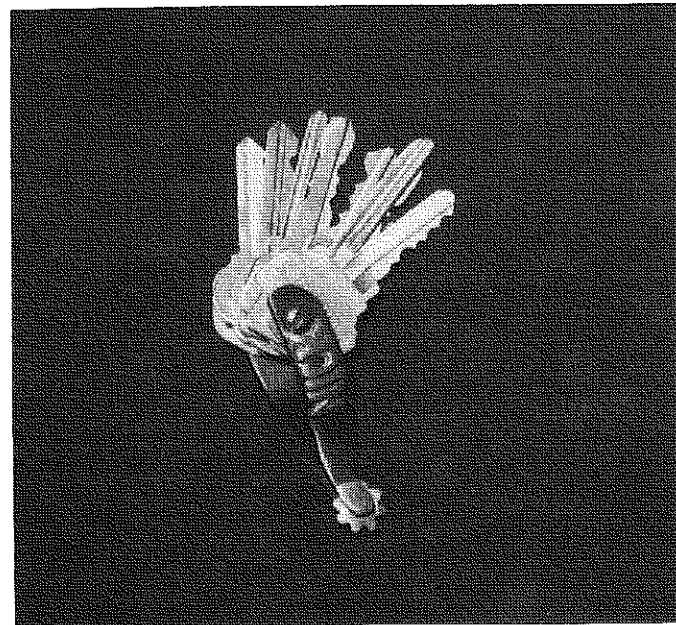

Coming in December:

Future Programs of Agriculture Education

Names of Plants

Have you had a problem teaching plant names? I solved the problem! One way is to make thermal slides. I needed a prepared slide of each plant to be identified, the common name, scientific name and its pronunciation, a transparency film and master, slide frames (35mm), an iron, an overhead projector and a homemade projection frame.

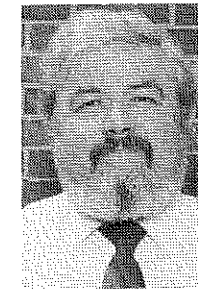

By ROBERT G. KEENAN

(Editor's Note: Mr. Keenan is Department Chair of Vocational/Industrial Education at Lansdowne High School, Baltimore, Maryland 21227.)

The first step is to type (or write) the common name in one square on the transparency master (see detail A), the scientific name in another and the pronunciation of the scientific name in a third square. Place several items on the sheet before you make a transparency. After making a transparency, cut the pieces into appropriate sizes and mount in a 33mm frame. Seal the frame with an iron. Caution: too hot an iron will put undesired marks on the transparency film. After each of the three slides are mounted, give them a number (I.D. slide-1: Common name - 1a, Scientific name - 1b, pronunciation - 1c). After this process, they are filed for easy access. After the students enter the room, the slides are projected on a screen. I use an overhead projector with a homemade mask (see detail B). A slide projector may be used, but there is an advantage to seeing all four items at once. I place little flaps on my mask to allow for flexibility.

By doing one plant per day, this allows time for students to settle down as they enter the class and prevents them from getting bored as we learn to identify 110-120 plants per year. I use Friday as a quiz for the plants learned the past week and use an overall quiz, as necessary.

Made of a Transparency Mounting Frame

Cover frame with a piece of cardboard. Cut out squares just a little smaller than a 35mm slide mount. I put some flaps on the cardboard to cover up the unwanted slot. This was done for flexibility.

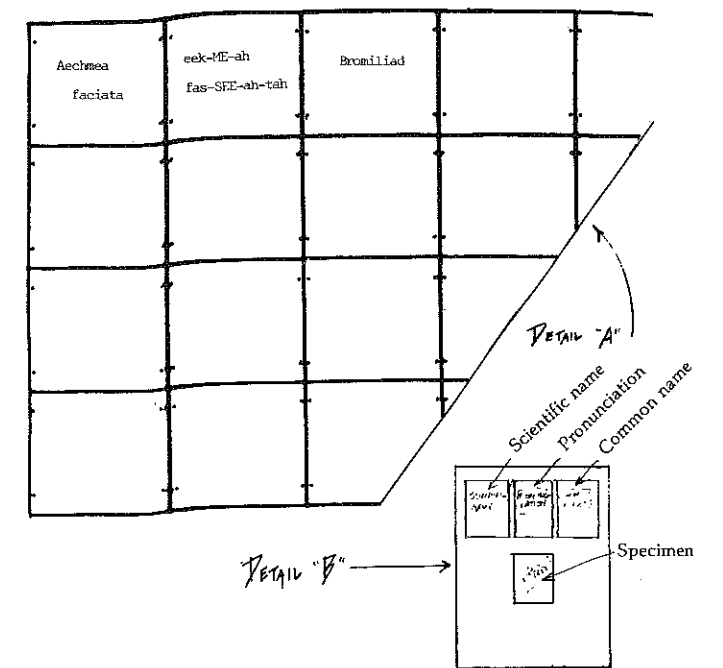

Author Reference for Teaching Tips

Jerry Schwochow
Horticulture Instructor
Vanguard JVS
1306 Cedar St.
Fremont, OH 43420

Colleen Garrett
Animal Care Instructor
Toledo Zoo
2700 Broadway
Toledo, OH 43608

Tom Oglesby
Production Agriculture Instructor
Hillsboro HS
358 W. Main St.
Hillsboro, OH 45133

Marvin Hemminger
Production Agriculture Teacher
Oregon-Clay High School
5665 Seaman
Oregon, OH 43616

Kerry S. O'Dell
Graduate Student
Department of Agricultural Education
203 Agricultural Administration Building
2120 Fyffe Road
The Ohio State University
Columbus, OH 43210-1099

Stories in Pictures

Teaching Tips Improve Instruction

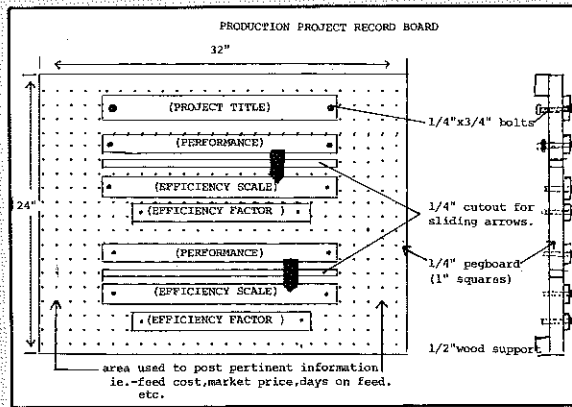

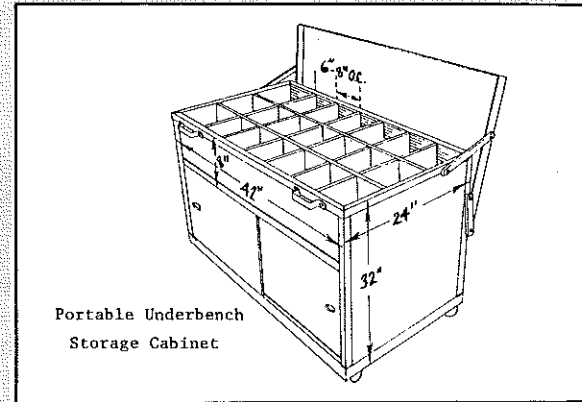

Do-it-yourself Visual Aids

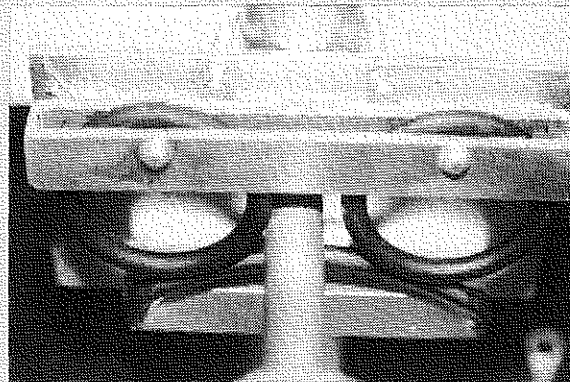

Labor-saving Devices



Inexpensive Class Projects



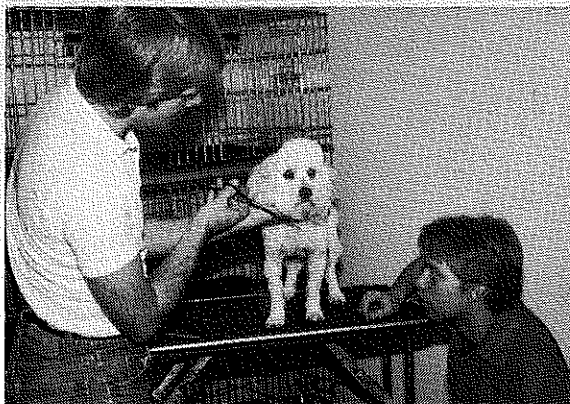

DANGER
Chemical Storage

Community Service Projects

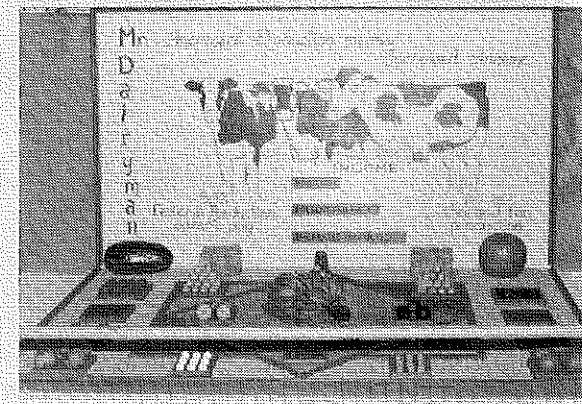

Use Community Resources



Public Relations Activities

(Photographs courtesy of Frederic Stillwagen, Pennsylvania; Thomas Siletto, Nebraska; Marven Busby, Arizona; Harold Strassburg, Wisconsin; Pam Petzel, Ohio; Robert Simmons, Louisiana.)